

Indoor shelter IS-1 / IS-2

Installation
Rev. 1.0
en • se

Dantherm[®]
CONTROL YOUR CLIMATE

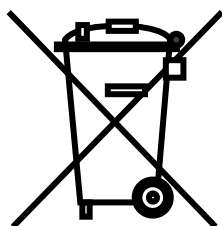

Der tages forbehold for trykfejl og ændringer
Dantherm can accept no responsibility for possible errors and changes
Irrtümer und Änderungen vorbehalten

Dantherm n'assume aucune responsabilité pour erreurs et modifications éventuelles"Delar

IS-1



IS-2



Content

Technical data.....	2
IS-1 Dimensions, front	3
IS-2 Dimensions, front	4
IS-1/2 Dimensions, left side	5
IS-1/2 Dimensions, right side	6
Option 1	7
Option 2.....	8
Option 3.....	9
Option 4.....	10
Delivery package.....	11
Parts.....	13
Installation preparation	20
Install base	21

Install poles.....	22
Install poles.....	23
Install top cover	24
Install side covers	25
Install end covers, option 1.....	26
Install end covers, option 2.....	27
Install end covers, option 3.....	28
Install end covers, option 4.....	29
Install interior items.....	30
Install cooling	31
Install covers.....	32
Install cables.....	33
Finalizing	34

Technical data

Technical data	
Flat pac delivery	Calculated assembling time: 2 mens work approximate 3 hours
Weight	IS-1: 110 kg IS-2: 250 kg + pallet 20 kg
Frame	Aluminium profiles
Floor	27 mm hard plywood with antistatic rubberized surface
Walls & roof	Sandwich construction with side and end panels of double-walled galvanized sheet-metal. Blue lacquered exterior. A layer of 25 mm polyurethane insulation between panels
U-value	0,96 W/m ² /°C
Outside measurement	IS-1: 1580x850x2250 mm (WxDxH) IS-2: 2350x850x2250 mm (WxDxH)
Inside measurement (wall to wall)	IS-1: 1530x800x2200 mm (WxDxH) IS-2: 2290x790x2190 mm (WxDxH)
Door opening	2230x2130 mm (WxH)
Door lock entrance	4-way espagnolette and ASSA key
Door lock service door	Push lock in upper position, 2 sliding safety catch
Air intake	Ø 400 mm
Exhaust air	Ø 315 mm via motorised damper
Fix points for CoolRack KS-1 RT 3	2 st (up and down)

ELECTRICAL CABLING WAY

Type: One 200 mm sheet metal cable ladder on the rear wall and one 100 mm sheet metal cable ladder in the roof.

FEEDER

Type: Roxtec Comlite 6-18

EXHAUST AIR DAMPER

Damper, type: SP315311, G-profile
Damper actuator: LM24 (24 VDC)

LIGHTING

Type: 230 V, 2x18 W luminance tube

IS-1 Dimensions, front

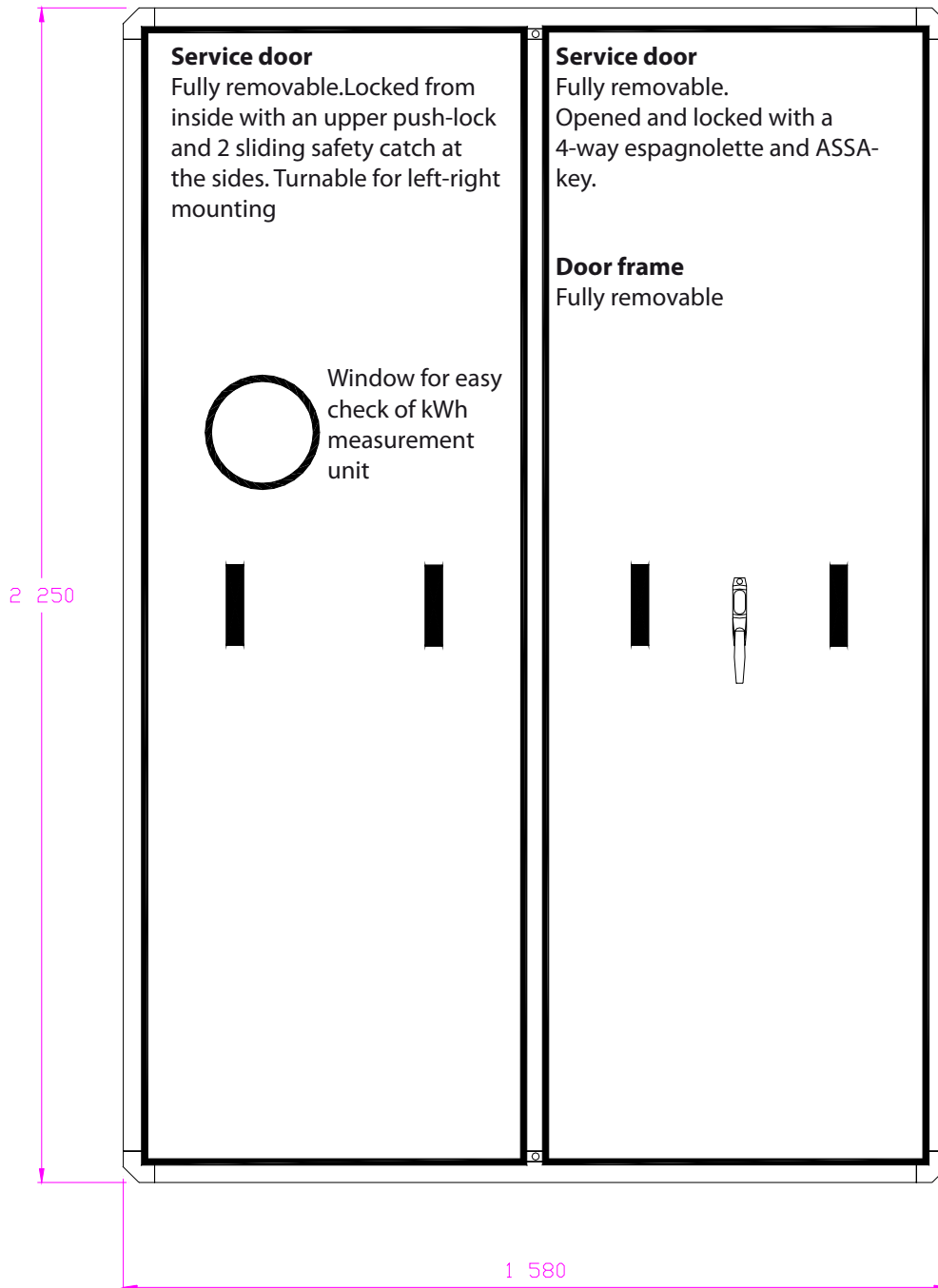

IS-2 Dimensions, front

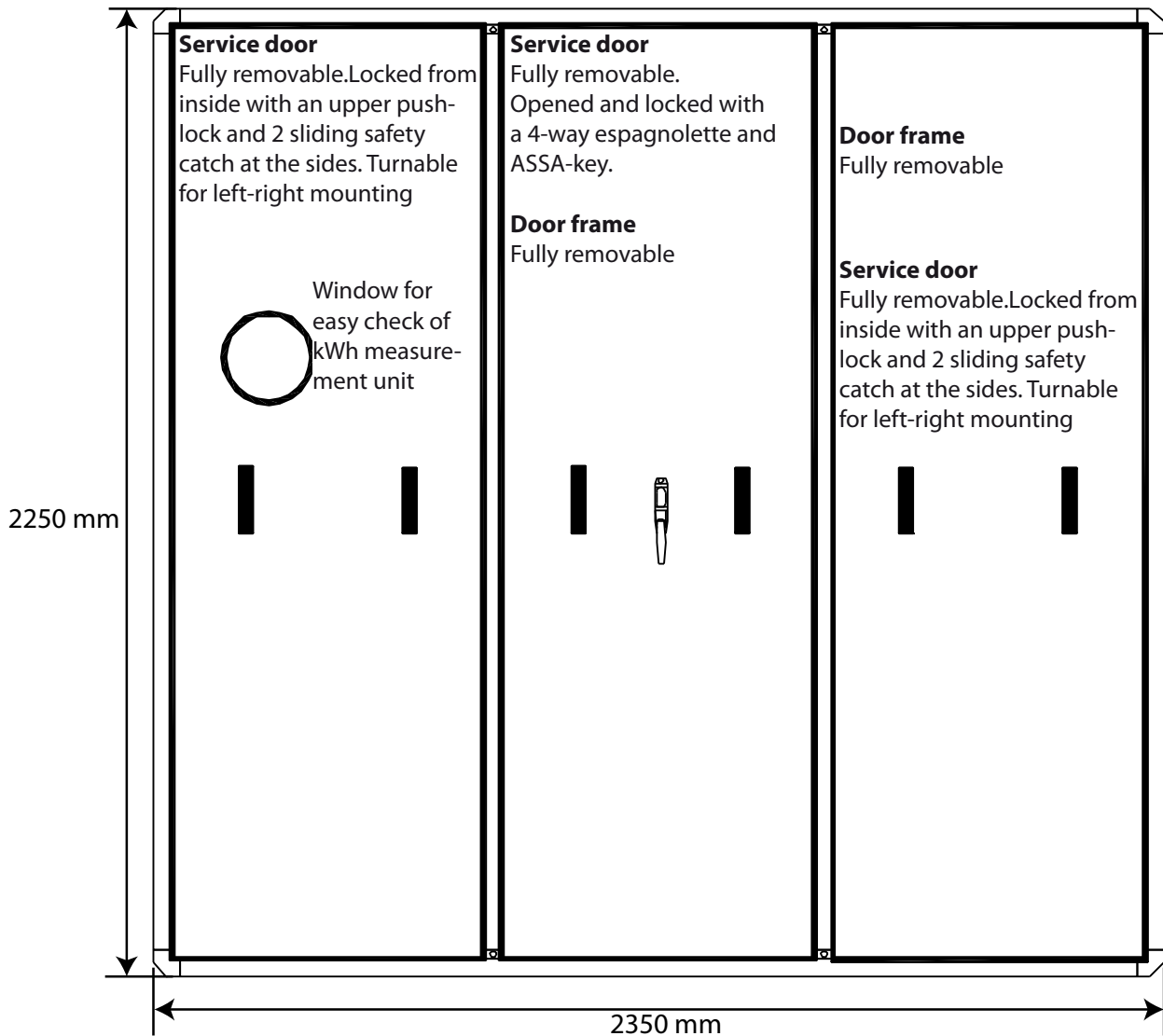

IS -1/2 Dimensions, left side

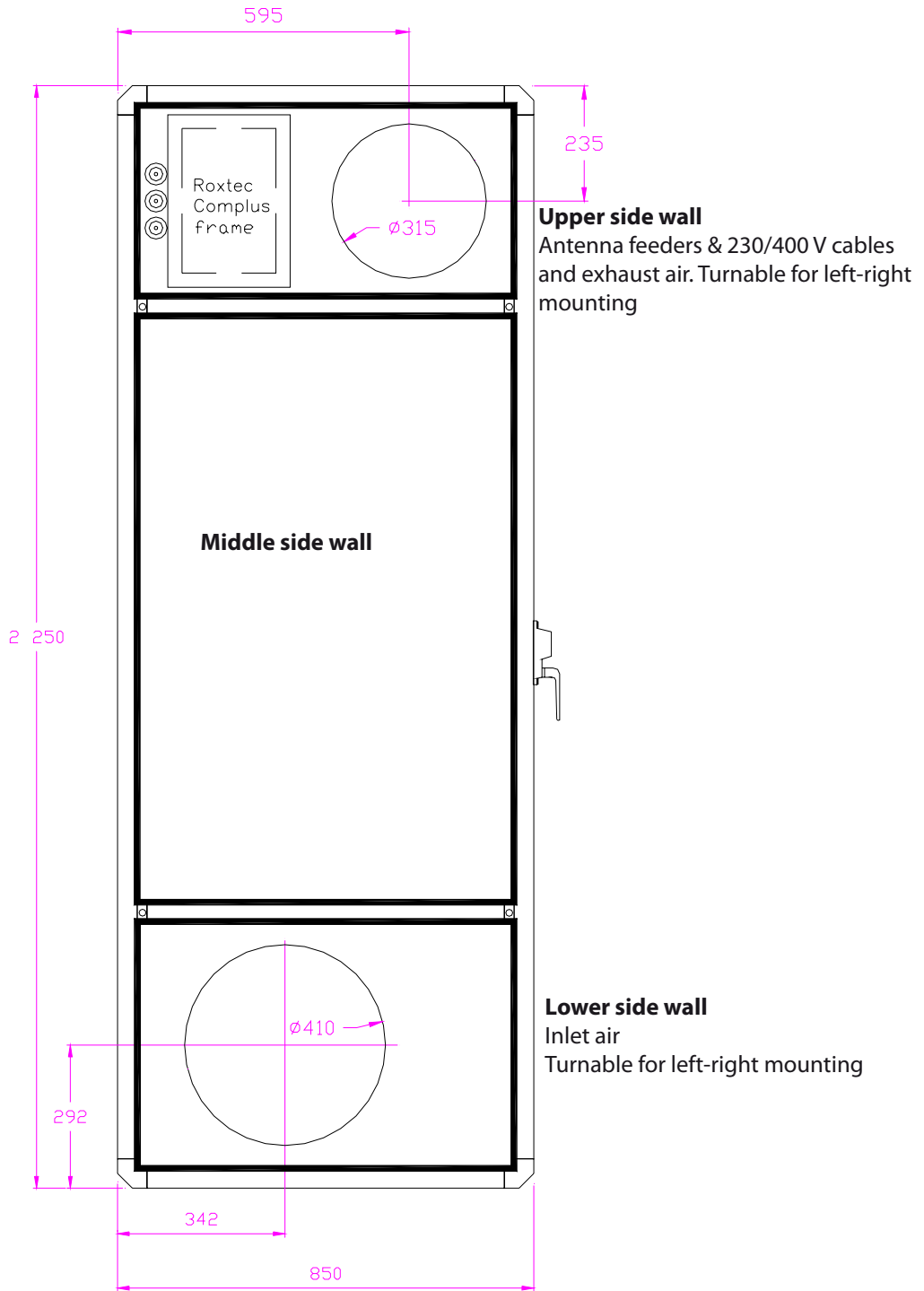

IS-1/2 Dimensions, right side

en

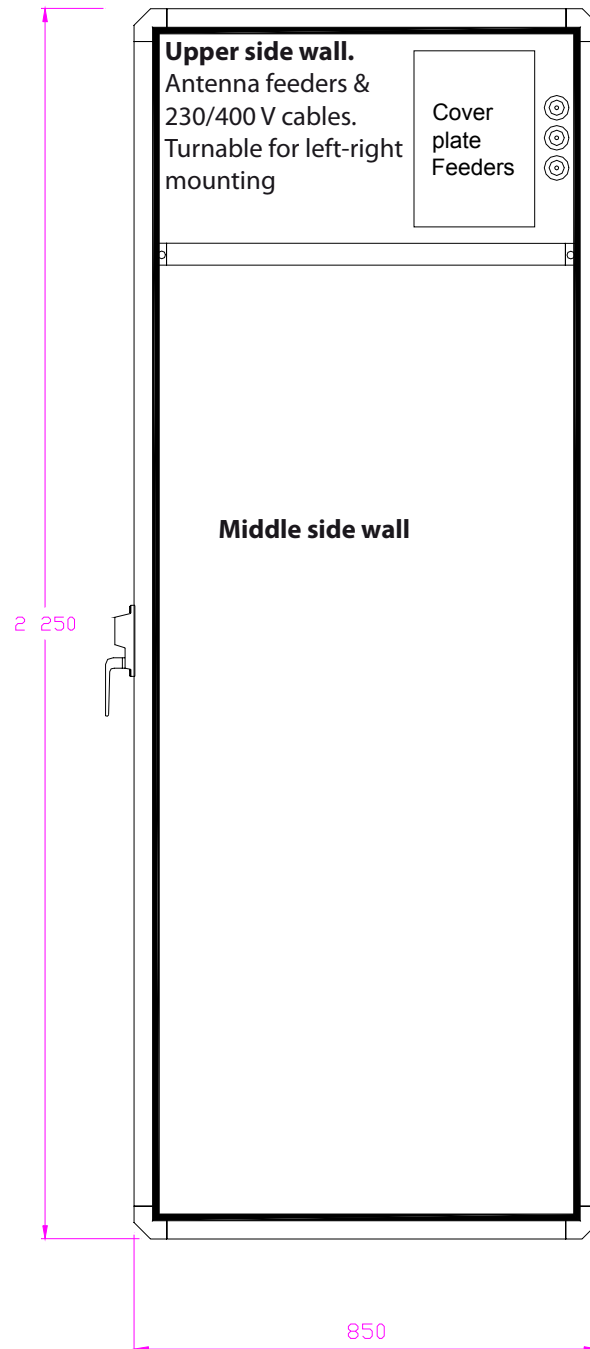

Option 1

Inlet air & exhaust air from the left.
Antenna feeders from left or right.
230/400 V cables from left or right.

IS-1

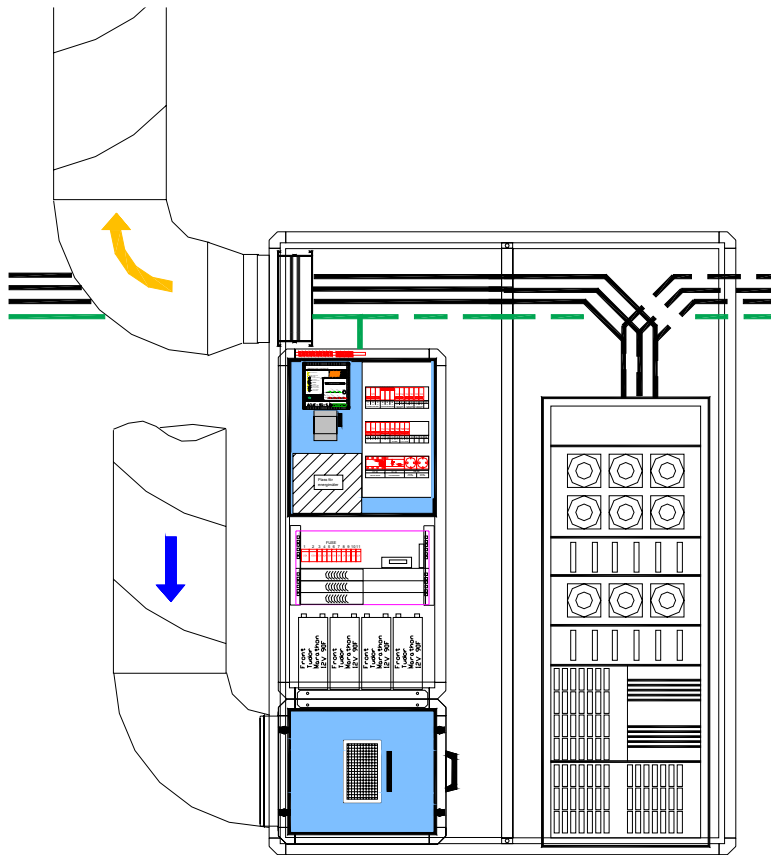

IS-2

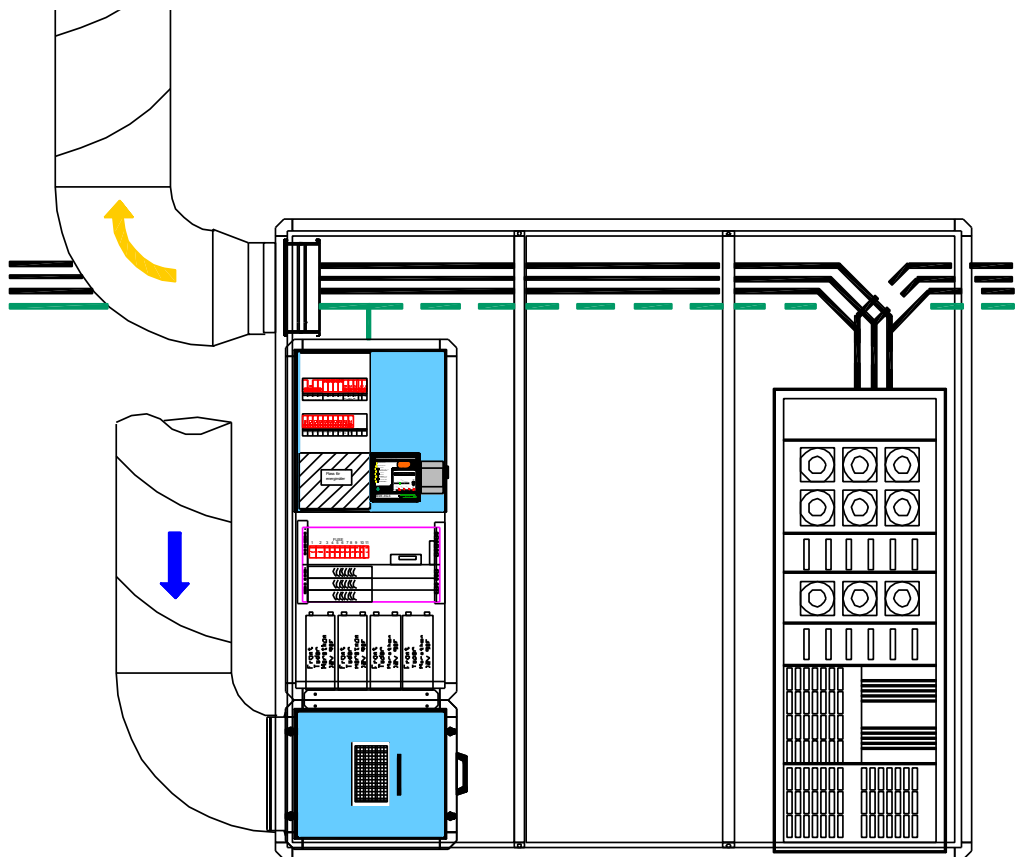

Option 2

Inlet air from the left.

Exhaust air from the right.

Antenna feeders from left or right.

230/400 V cables from left or right.

en

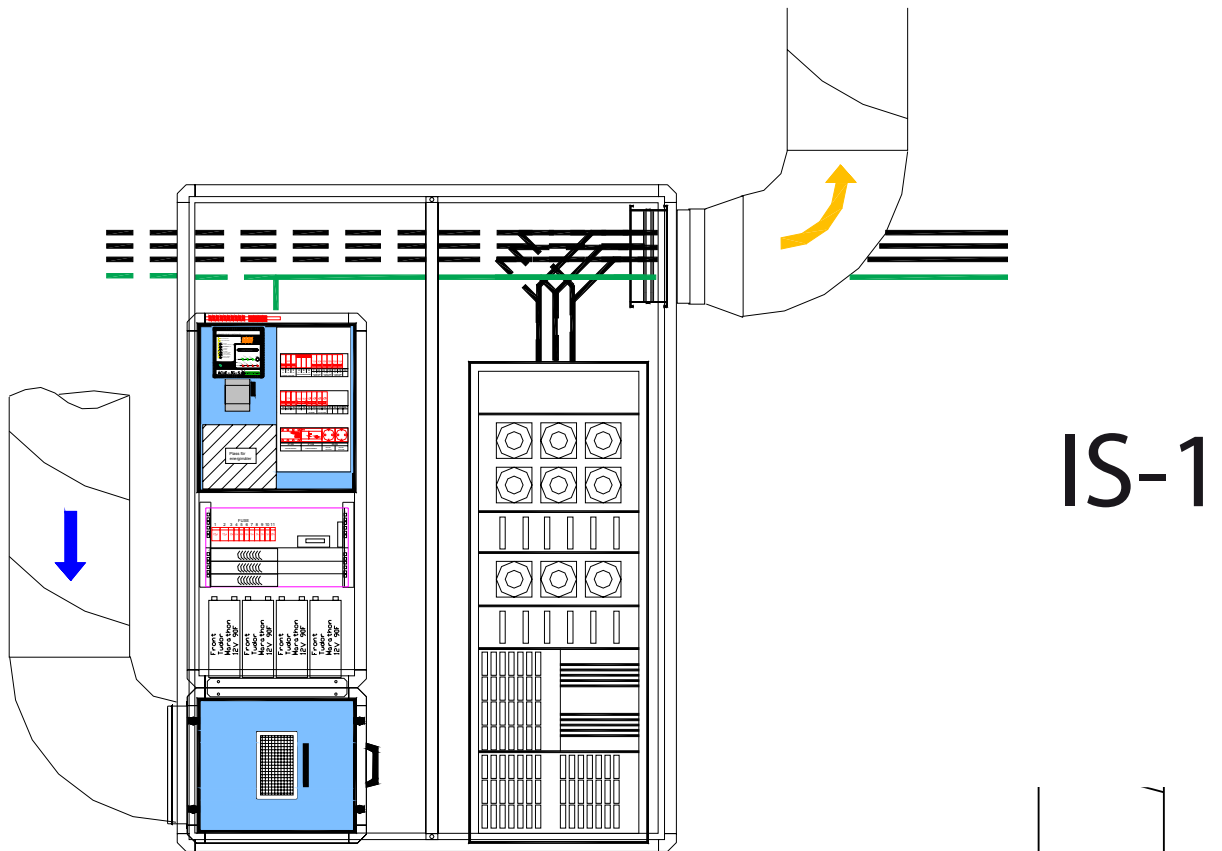

IS-1

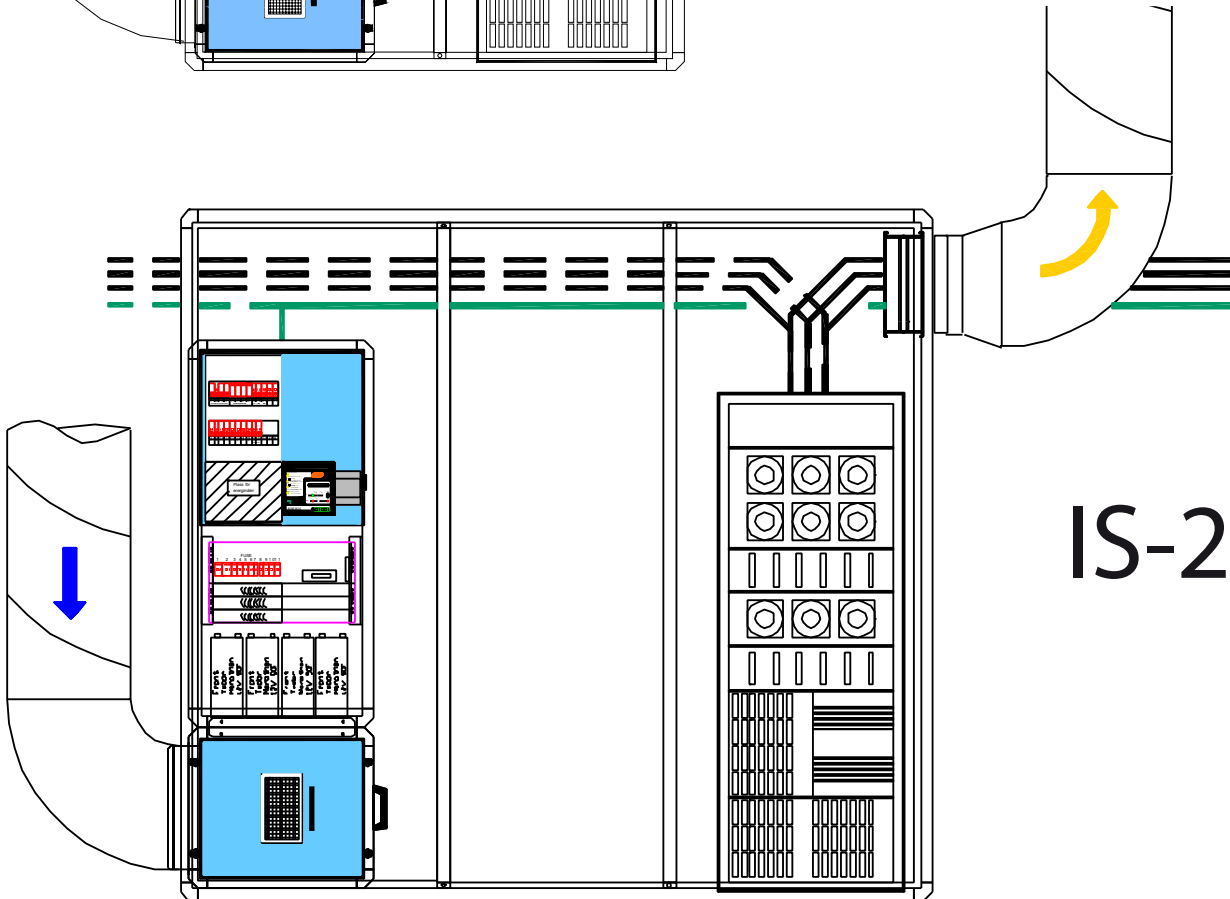

IS-2

Option 3

Inlet air & exhaust air from the right.
Antenna feeders from left or right.
230/400 V cables from left or right..

IS-1

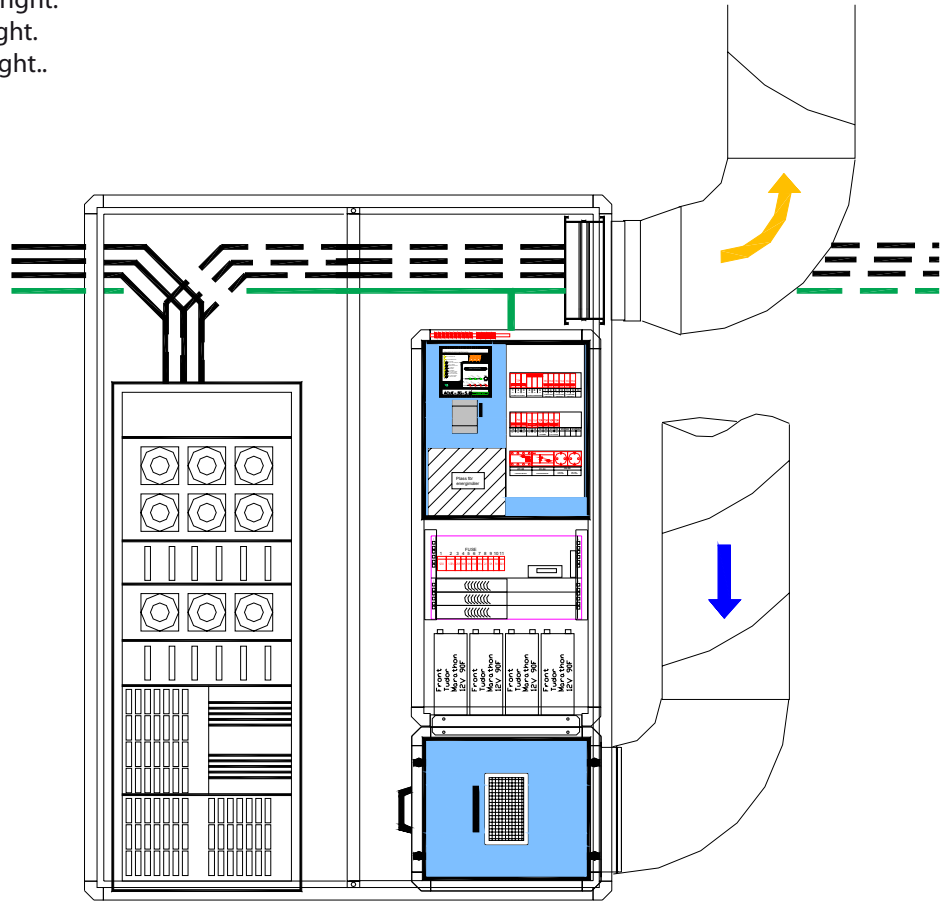

IS-2

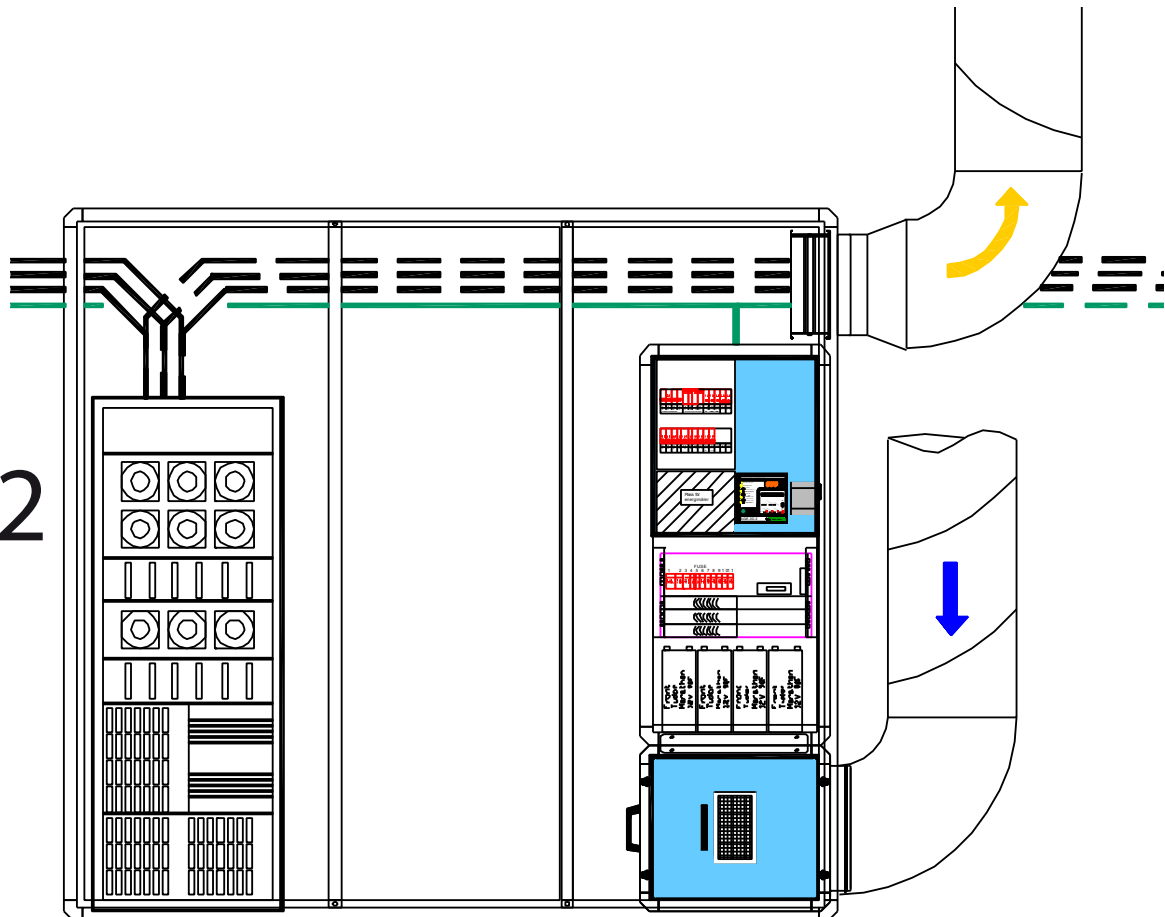

en

Option 4

Inlet air from the right. Exhaust air from the left.
Antenna feeders from left or right.
230/400 V cables from left or right.

en

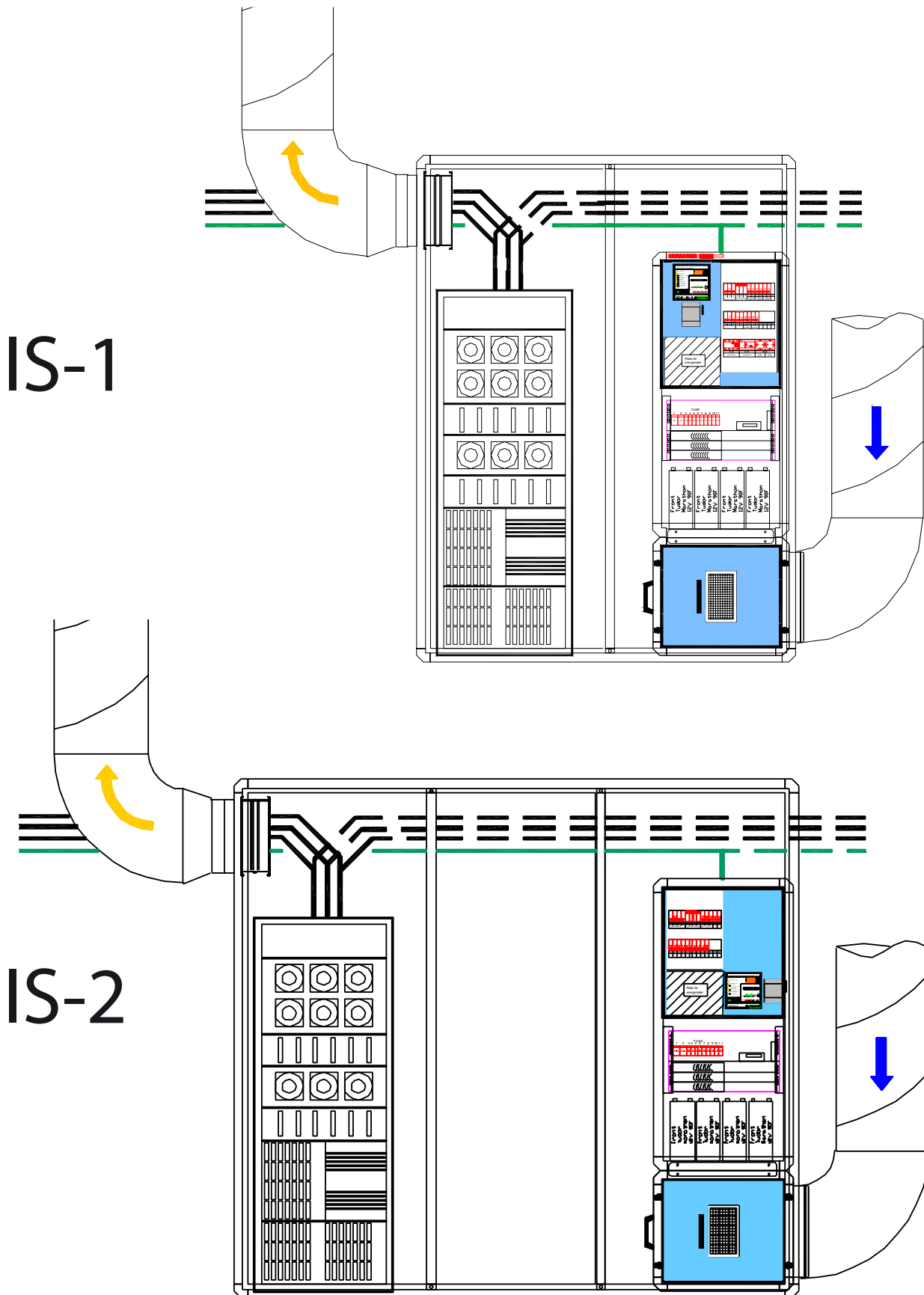

Delivery package

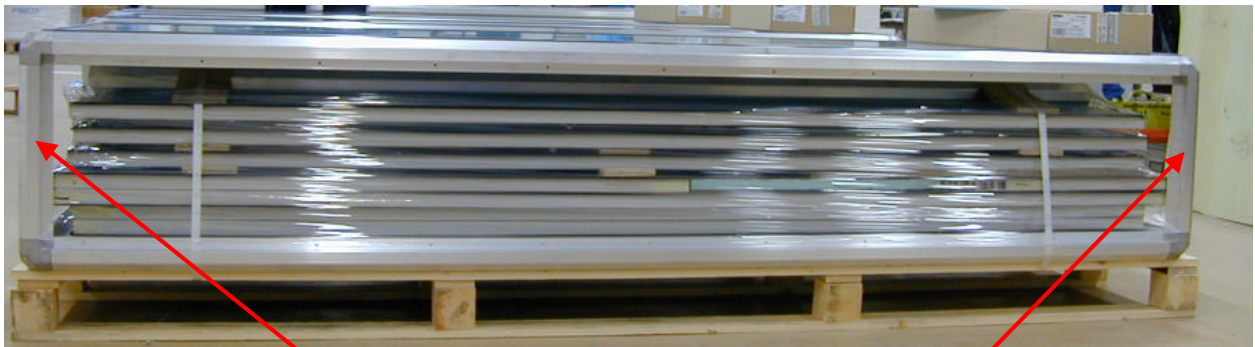





This four corners made of aluminium are only for the package and are not meant to be used in the building .

Indoor shelter, mounting instruction

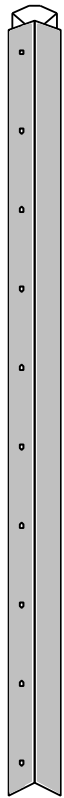

IS1 / IS-2 is equal assembled and mounted.
IS-1 has two doors
IS-2 has three doors

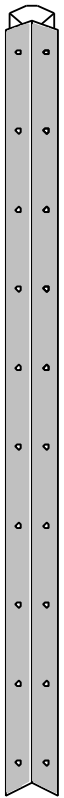
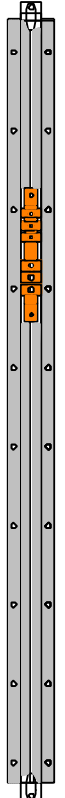
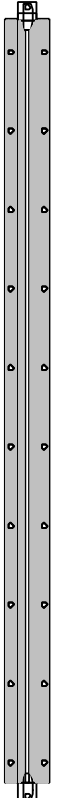
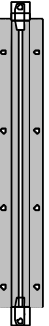

Parts

Item	Pos.	Description
	A1	<p>Front corner profile, 2 pcs. Turn the holes toward the side walls in the shelter. No holes toward the door opening.</p>
	A2	<p>Front door profile, 2 pcs. Place the guide bolt in the 7 mm hole in front of the roof and floor. Lock it by bolts.</p>
	A3	<p>Rear corner profile, 2 pcs.</p>
	A4	<p>Rear wall profile with earth bar, 1 pcs. To be placed after the first rear wall, close to Cool Rack, with the earth bar on top. Mounting with screws to the walls.</p>
	A5	<p>Rear wall profile, 1 pcs. To be placed between the rear walls. Mounting with screws to the walls.</p>
	A6	<p>Horizontal profile on side walls, 2 + 1 pcs. between the side walls depending on mounting alternative #1-4.</p>
	A7	<p>Cable ladder, 1 pcs. To be placed on the rear wall near the roof. Mounting with 8 pcs of screws.</p>

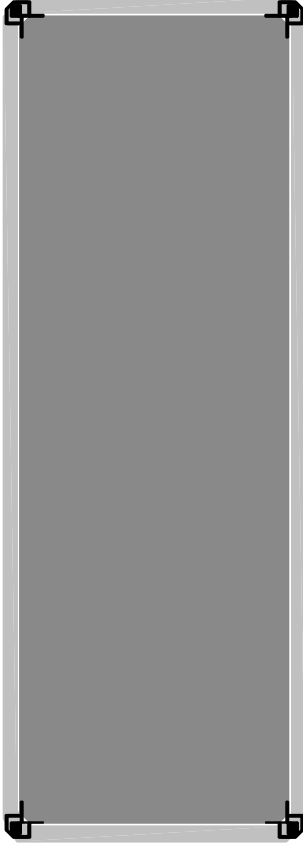
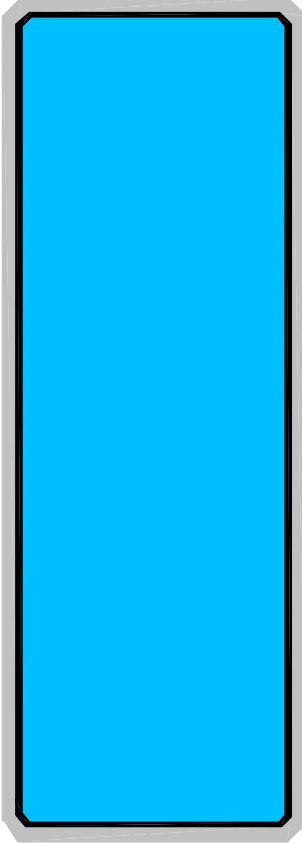
Parts

Item	Pos.	Description
	B1	Floor, 1 pcs. To be placed on a well levelled area. Use at least 6 pcs of rubber plates as vibration absorber. Turn it with the 7 mm holes toward the door opening .
	B2	Roof, 1 pcs. Ready mounted with 100 mm cable ladder and (if delivered) a breaker for the lighting. Turn it with the 7 mm holes toward the door opening .

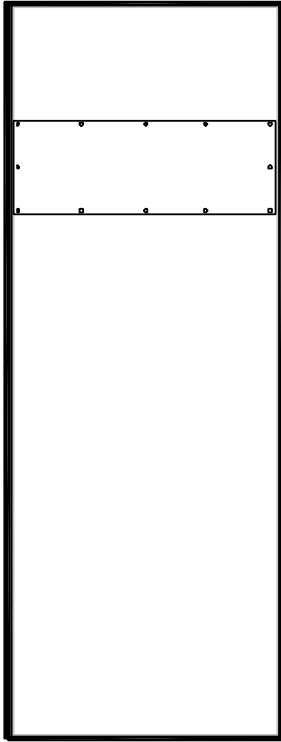
Parts

Item	Pos.	Description
		<p>Rear wall, 3 pcs. The extra mounting plate is used for fixing CoolRack and radio base.</p>

Parts

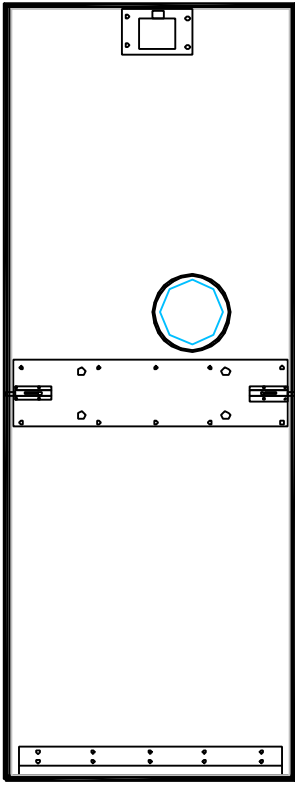
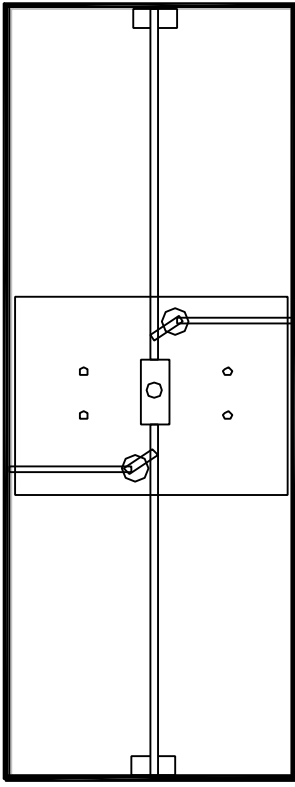
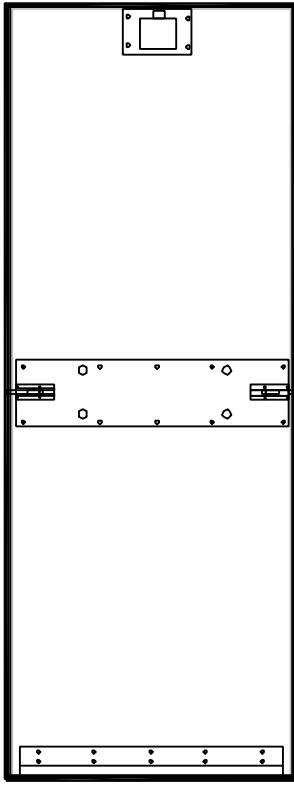

Item	Pos.	Description
	<div style="border: 1px solid black; padding: 5px; text-align: center; width: 40px; height: 40px; margin: 0 auto;">B5</div>	<p>Door with window, 1 pcs To be placed in front of Cool Rack. The window (option) is used for checking of a kWh measurement unit. Turn the lock upwards.</p>
	<div style="border: 1px solid black; padding: 5px; text-align: center; width: 40px; height: 40px; margin: 0 auto;">B6</div>	<p>Door with espagnolette lock, 1 pcs Place this door in the middle. Cylinder lock is not included in the delivery.</p>
	<div style="border: 1px solid black; padding: 5px; text-align: center; width: 40px; height: 40px; margin: 0 auto;">B7</div>	<p>Door, 1 pcs. Turn the lock upwards..</p>

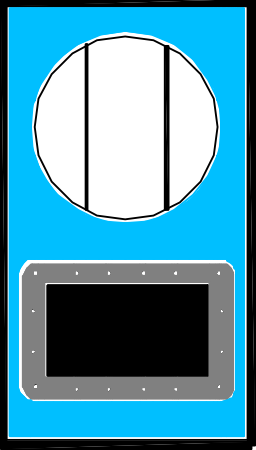
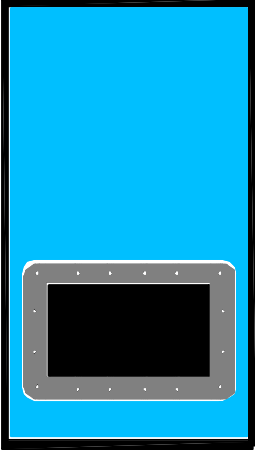
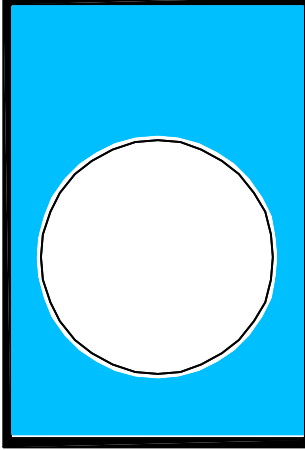
Parts

Item	Pos.	Description
	<div style="border: 1px solid black; padding: 5px; text-align: center;">B8</div>	<p>Upper side wall with damper and Roxtec cable frame, 1 pcs. To be placed where exhaust air go out. Cables in-out via Roxtec Comlite 6/18</p>
	<div style="border: 1px solid black; padding: 5px; text-align: center;">B9</div>	<p>Upper side wall with Roxtec cable frame, 1 pcs. To be placed on the opposite upper side wall as an alternative cable in-out via Roxtec Comlite 6/18.</p>
	<div style="border: 1px solid black; padding: 5px; text-align: center;">B10</div>	<p>Air intake wall, 1 pcs. To be placed where intake air come in. Left or right side turnable.</p>

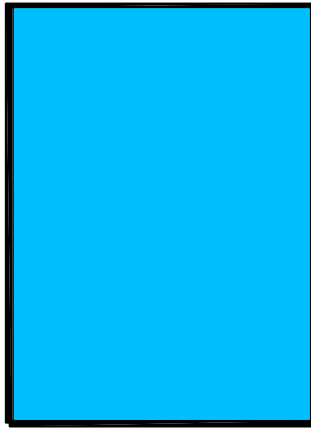
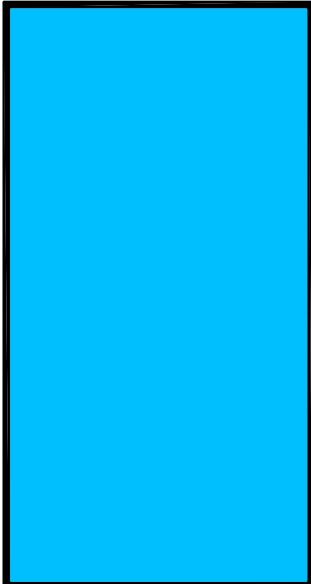
Parts

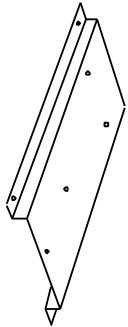
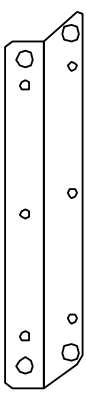
Item	Pos.	Description
	B11	Side wall, 1 pcs. To be placed between the walls B8 – B10
	B12	Side wall, 1 pcs. To be placed between the walls B8 – B10

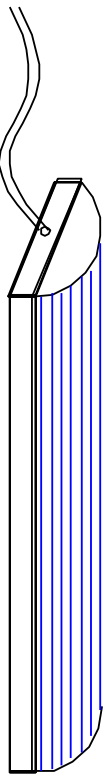
Item	Pos.	Description
	<div style="border: 1px solid black; padding: 5px; text-align: center; width: 40px; margin: 0 auto;">C1</div>	<p>Mounting detail with room temp. sensor and smoke detector (if used), 1 pcs. To be placed in the roof close to the area of exhaust air.</p>
	<div style="border: 1px solid black; padding: 5px; text-align: center; width: 40px; margin: 0 auto;">C2</div>	<p>Mounting iron for Cool Rack, 2 pcs. OBS! One is already mounted on Cool Rack at delivery. The other is fixed with 2 pcs. M6 bolts in the fan unit and 3 screws to the floor</p>
	<div style="border: 1px solid black; padding: 5px; text-align: center; width: 40px; margin: 0 auto;">C3</div>	<p>Rubber plate 100x100 mm, 12 pcs. Place them under the floor aluminium profile to prevent bad levelling and as sound absorber. Use at least 6-8 pcs. under the floor. Important ! Place 1 rubber plates under the Cool Rack's each front and rear corner (seen from the radiobase) when You place the CoolRack.</p>
	<div style="border: 1px solid black; padding: 5px; text-align: center; width: 40px; margin: 0 auto;">C4</div>	<p>Roof lighting, 1 pcs. To be placed in the roof with 4 screws. See four markings in the roof. Fix the cable BELYSNING on the cable ladder in the roof. Connect the cable in the lighting.</p>

Installation preparation

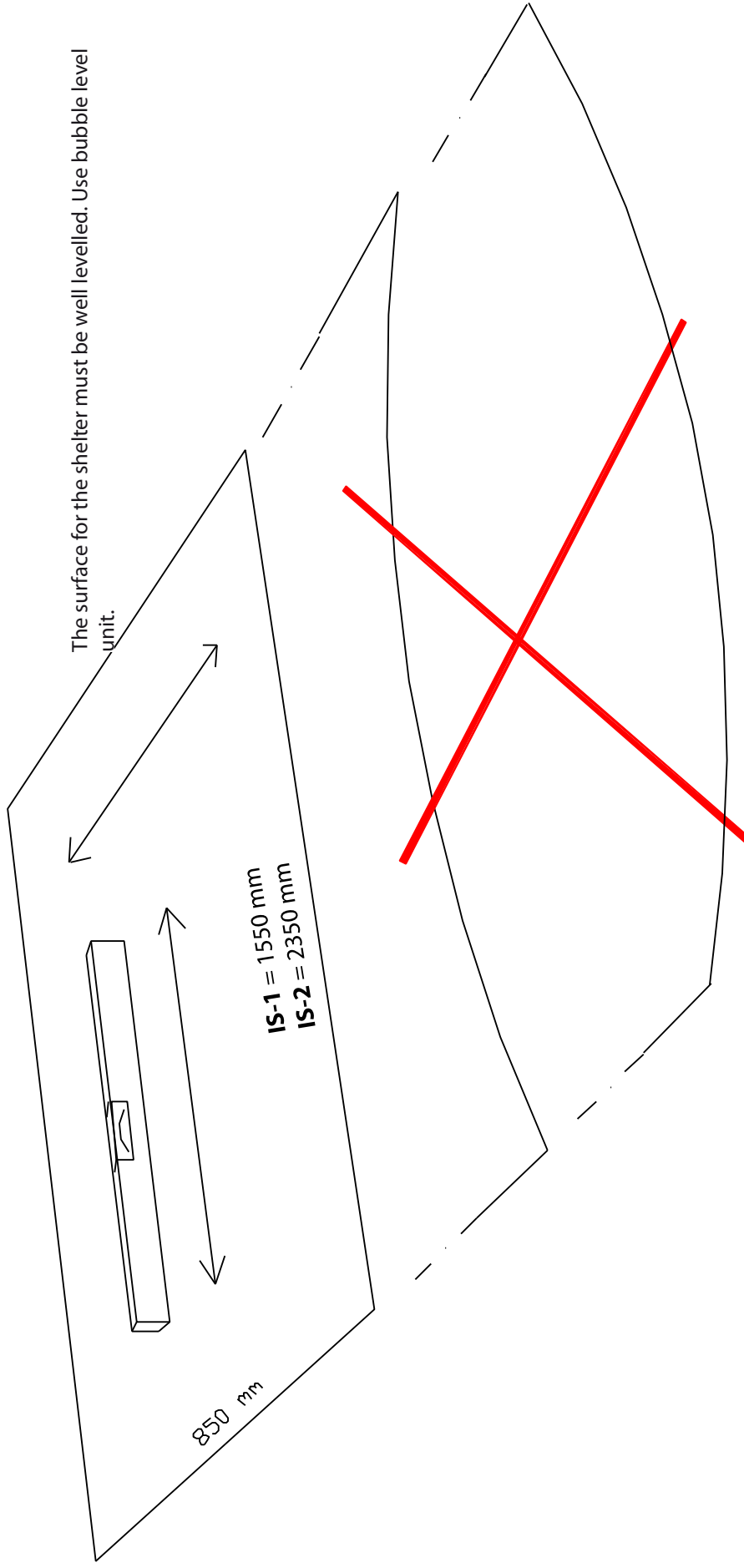

The surface may not have curves.

Install base

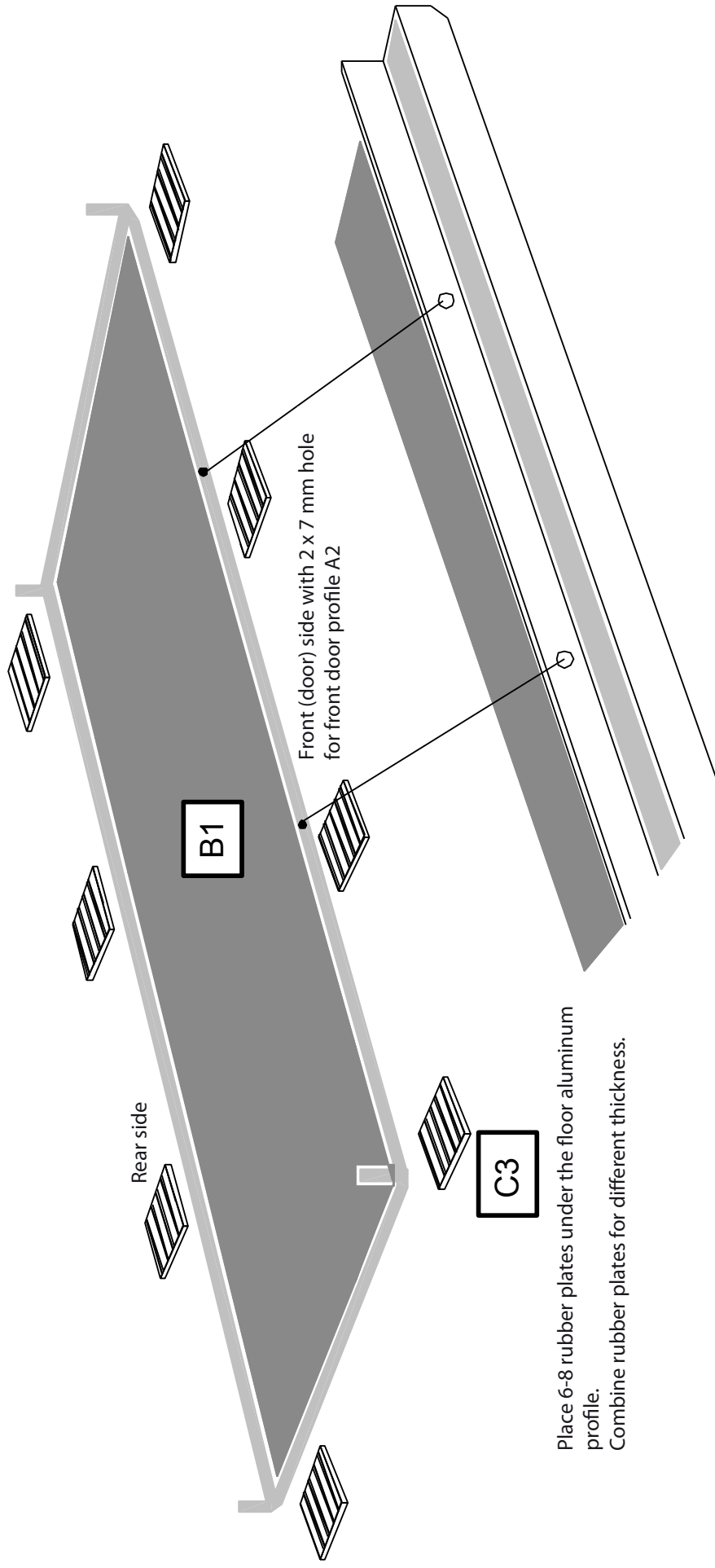

Place 6-8 rubber plates under the floor aluminum profile.
Combine rubber plates for different thickness.

Install poles

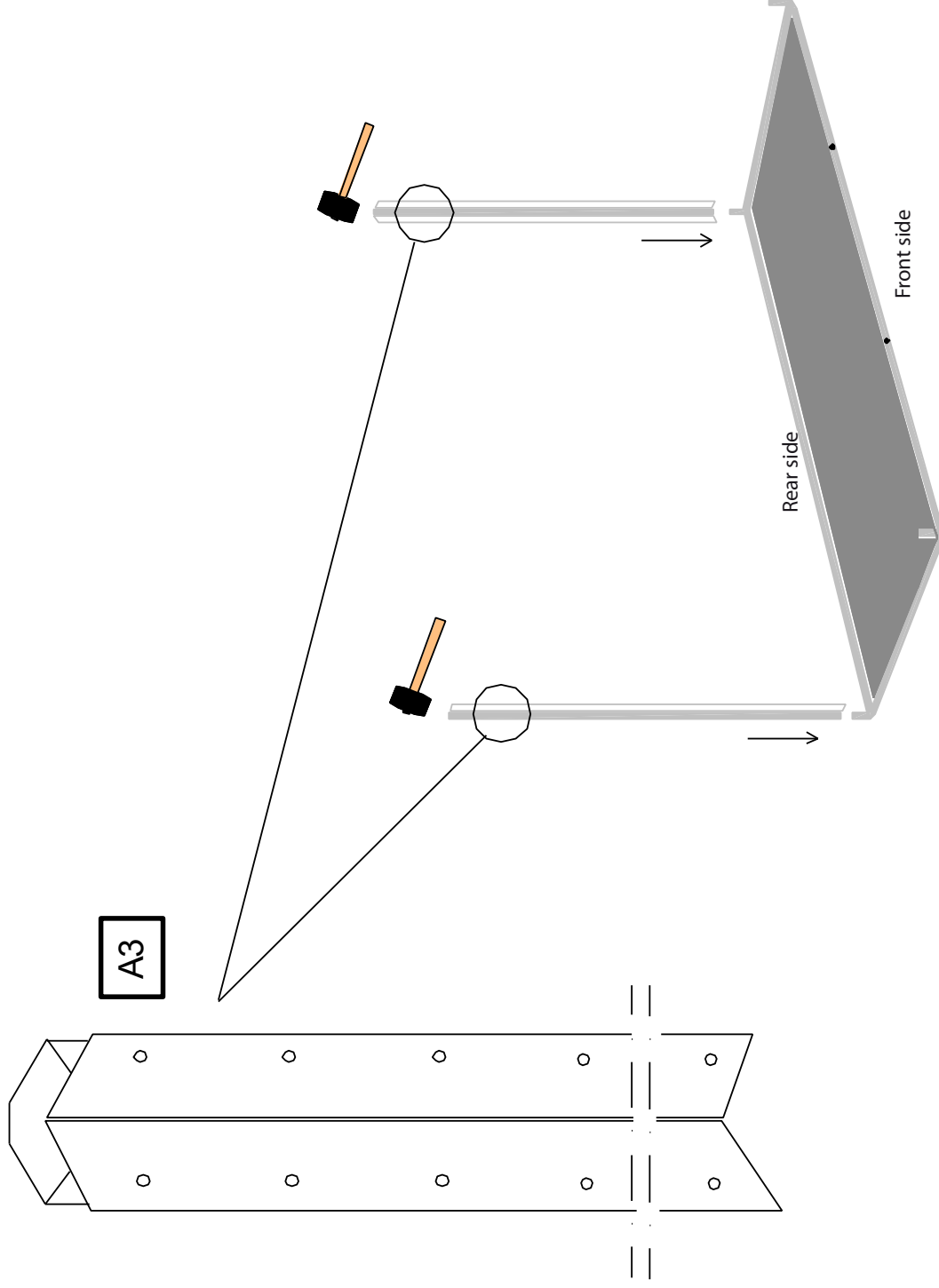

Install poles

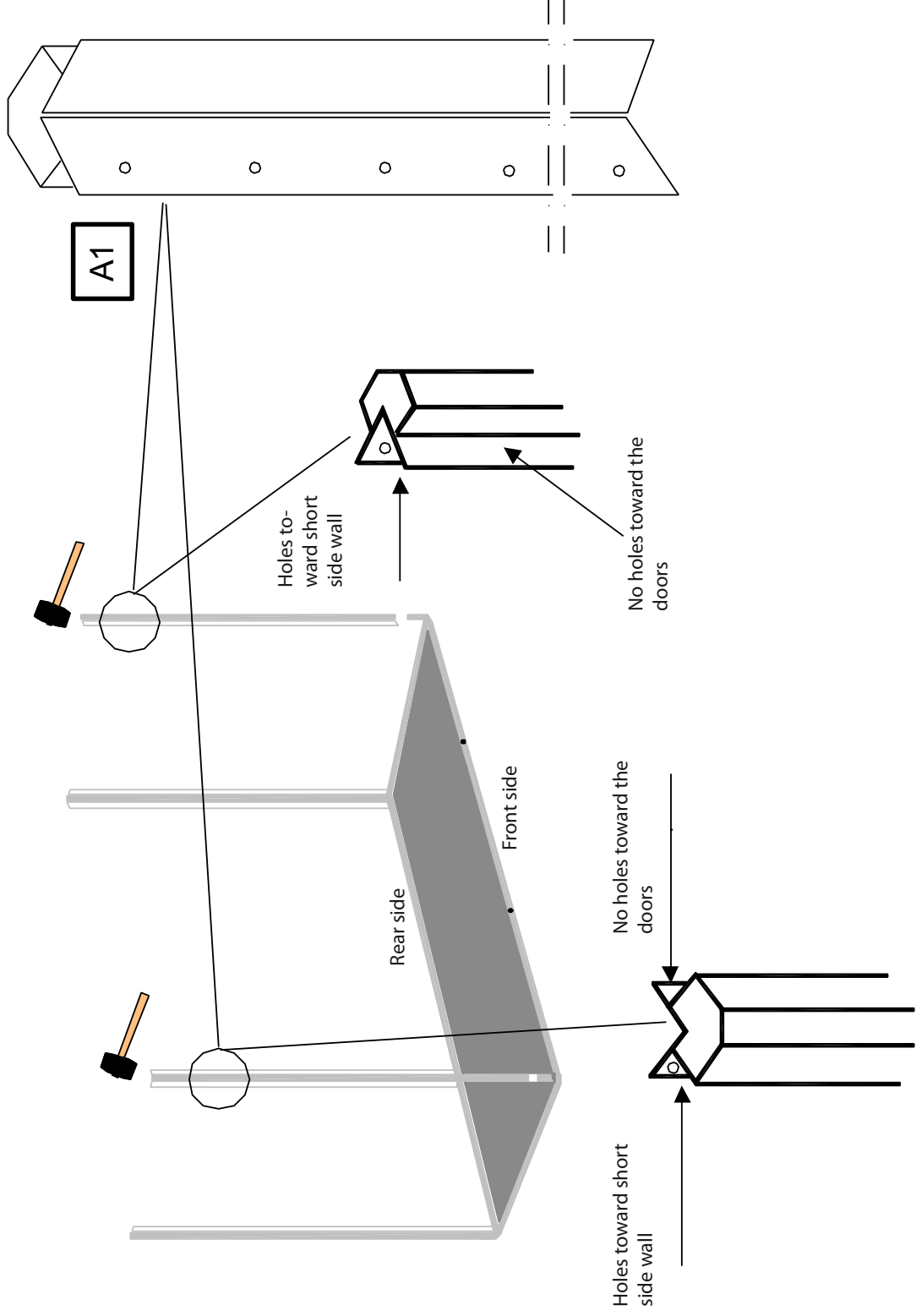

Install top cover

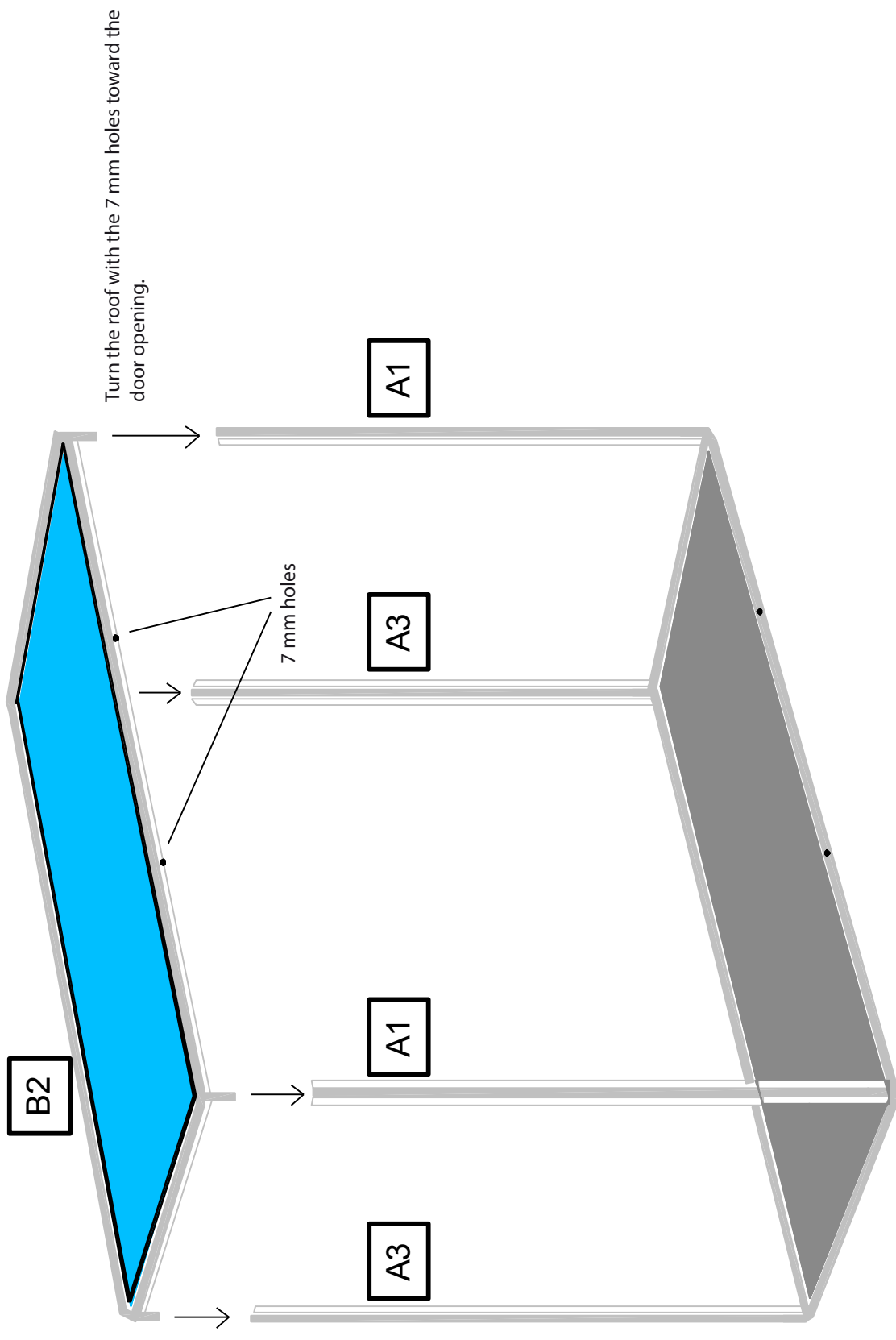

Install side covers

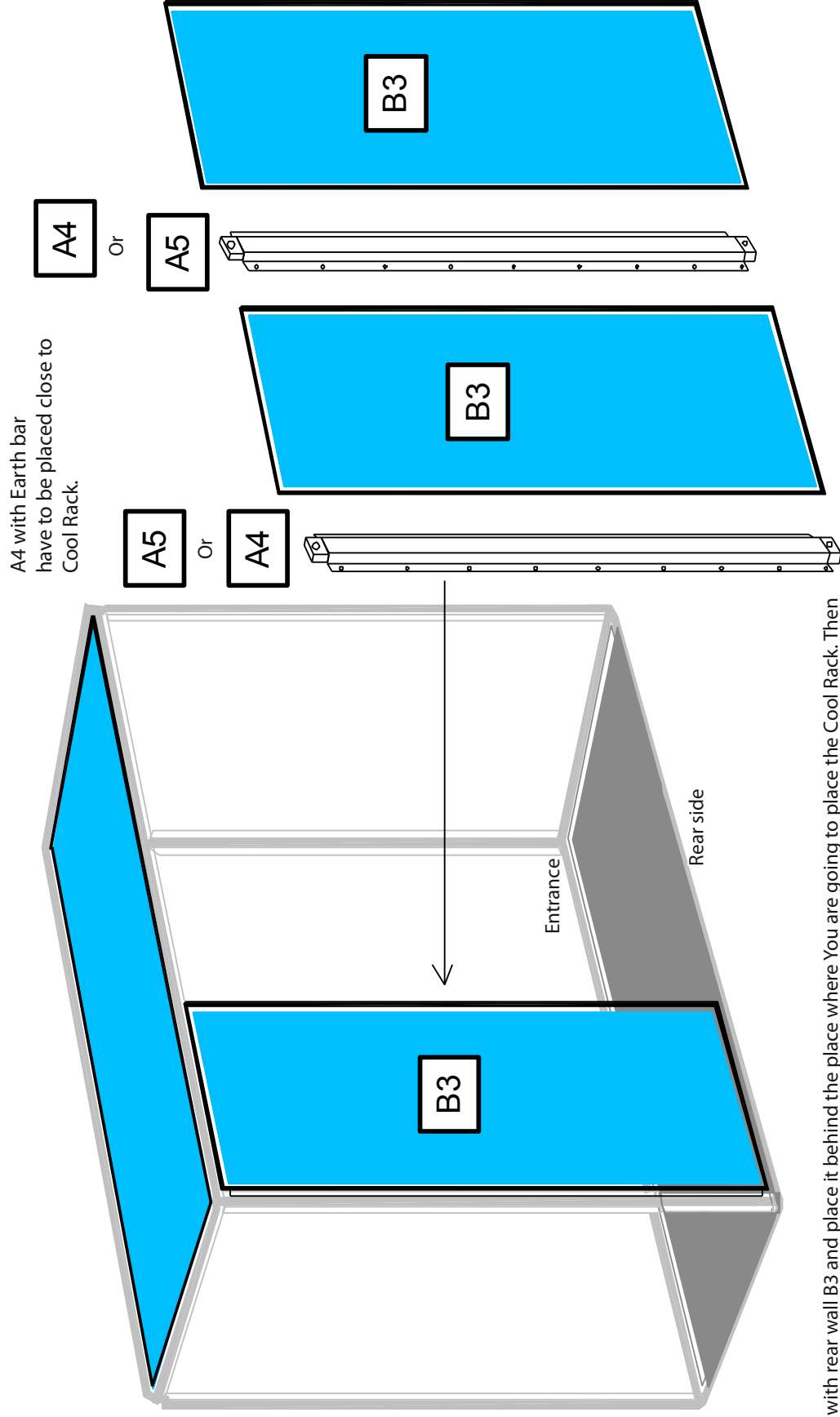

Start with rear wall B3 and place it behind the place where you are going to place the Cool Rack. Then place the aluminium profile A4. Now, fix the wall with some screws. Continue with next rear wall B3 and aluminium profile A5. Fix again with some screws. Place the last rear wall B3 and then fix all the walls complete.

Install end covers, option 1

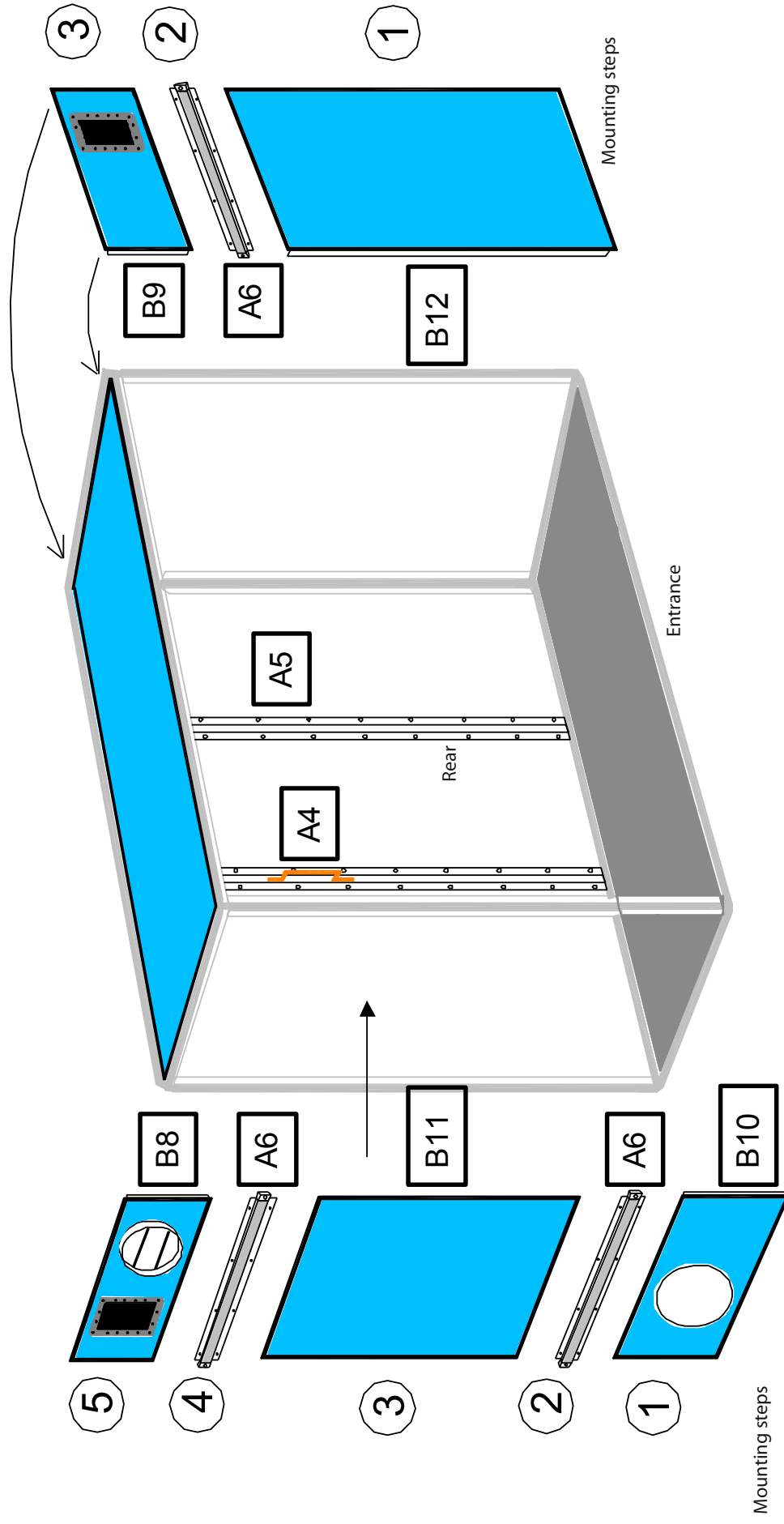

Install end covers, option 2

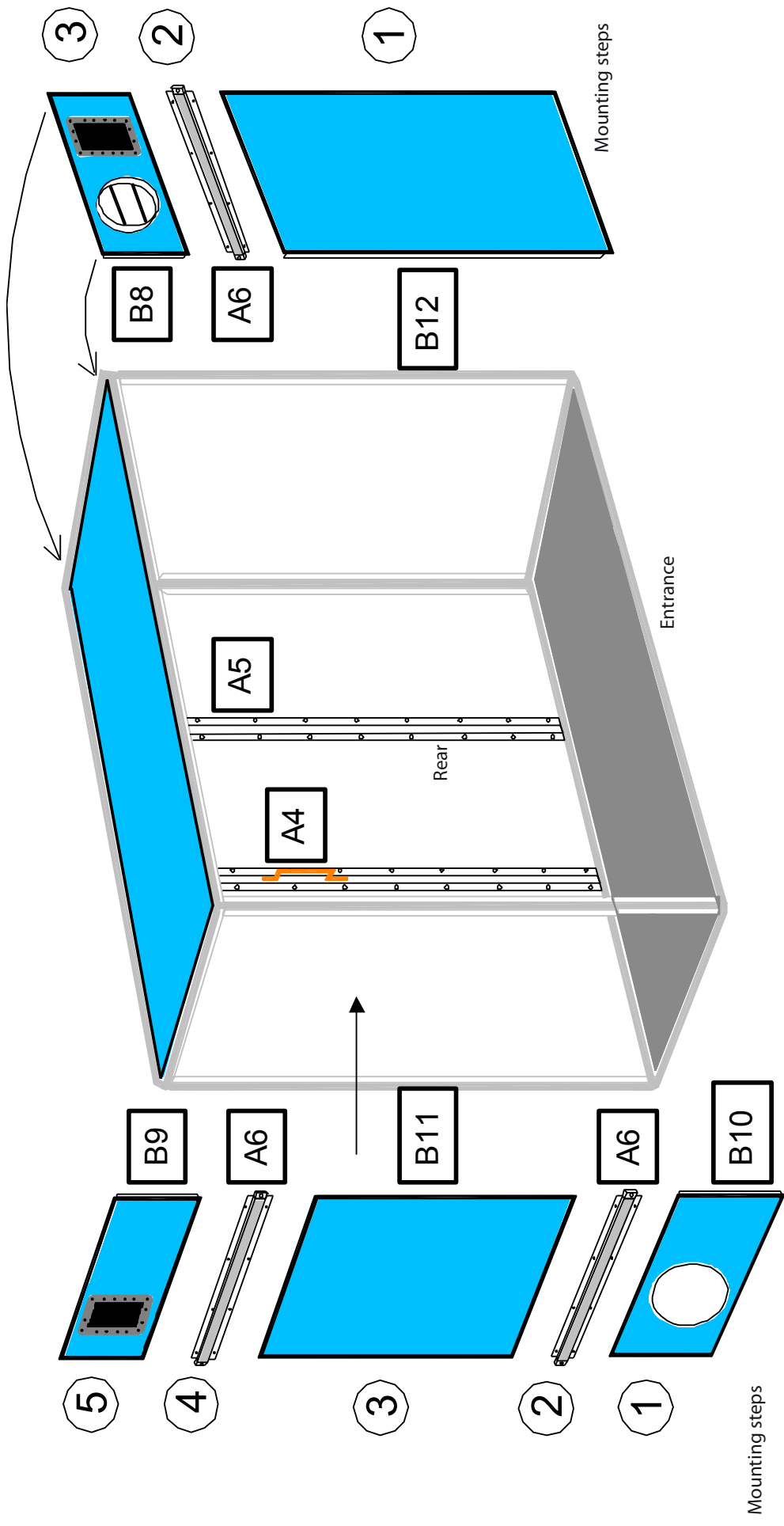

Install end covers, option 3

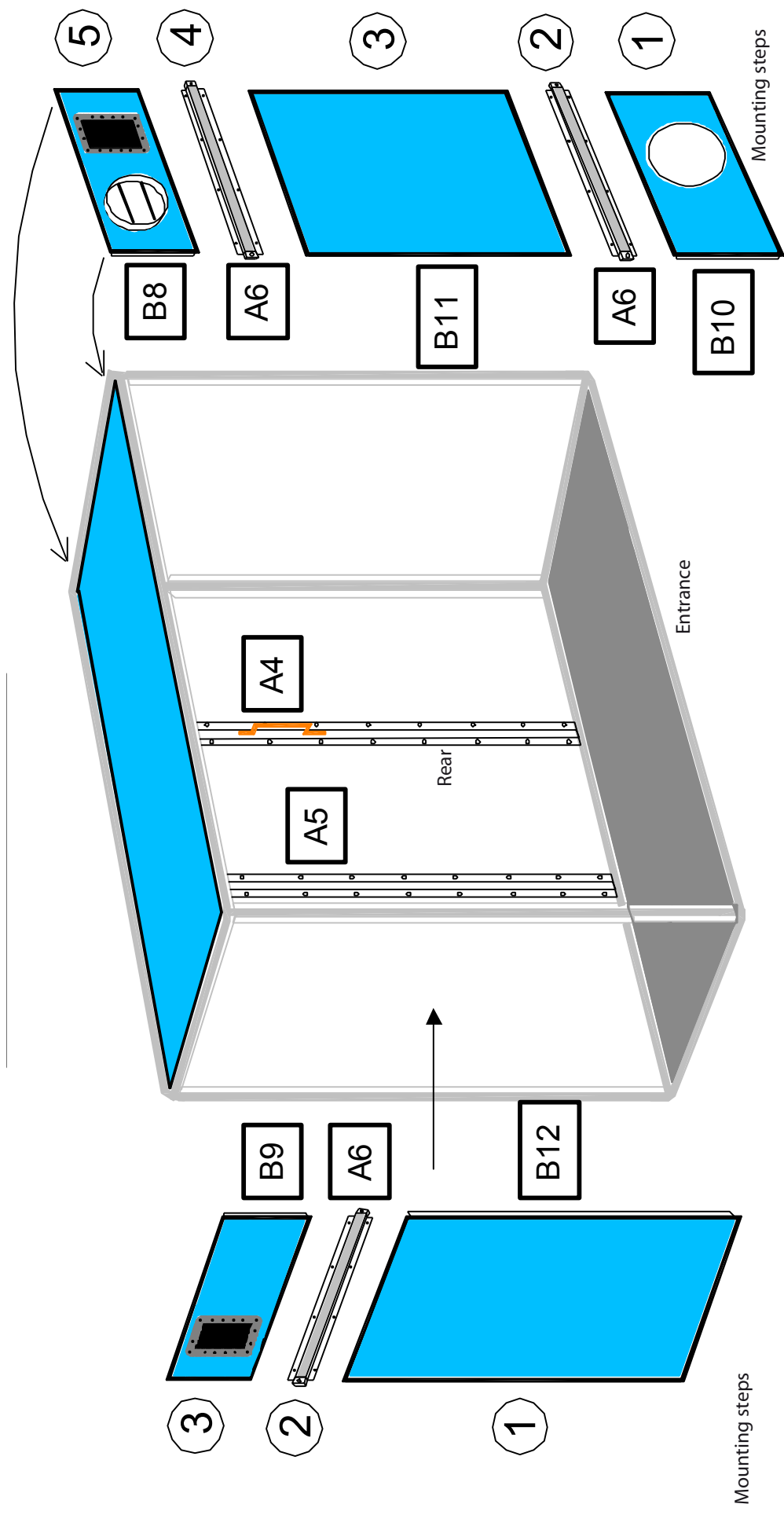

Install end covers, option 4

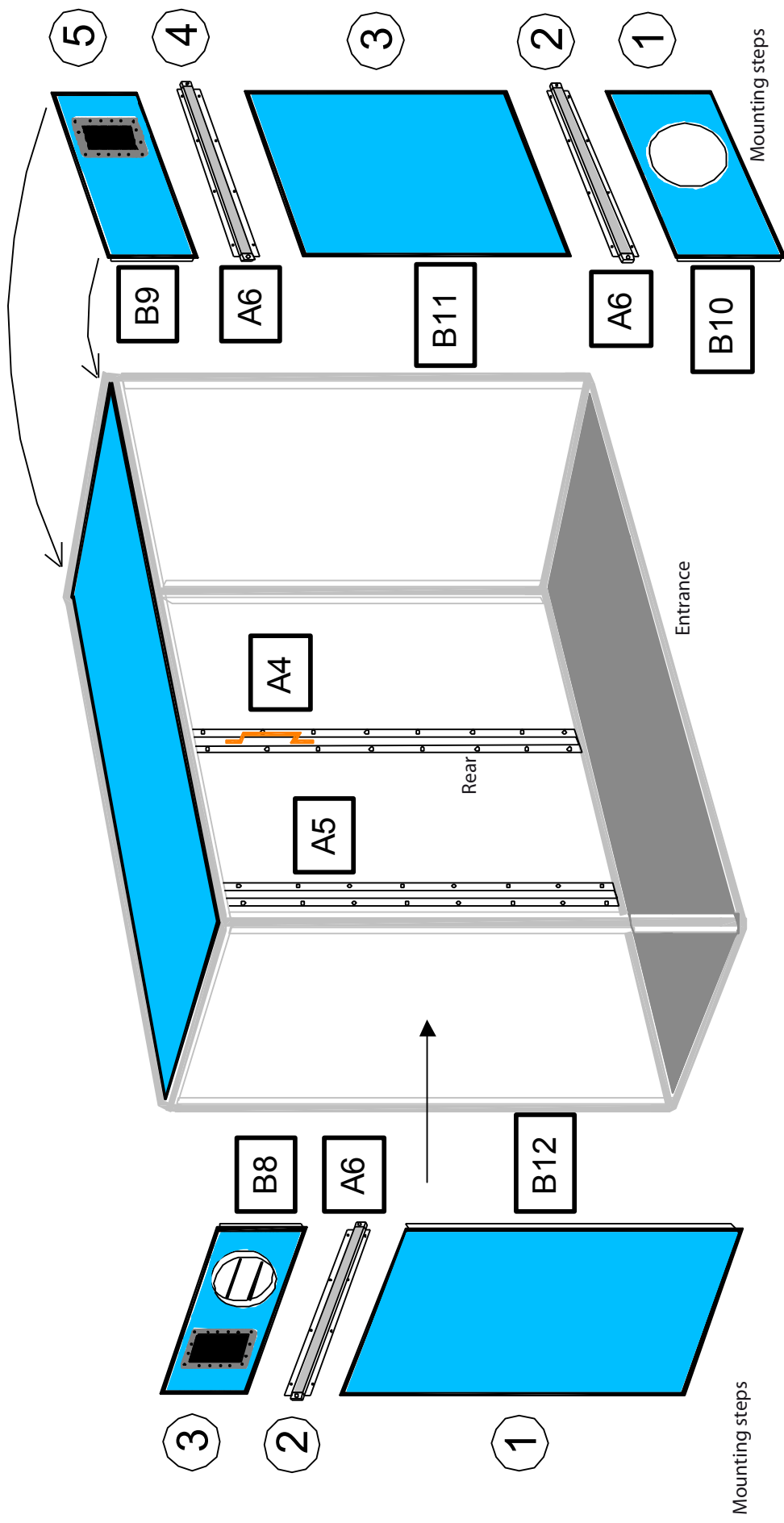

Install interior items

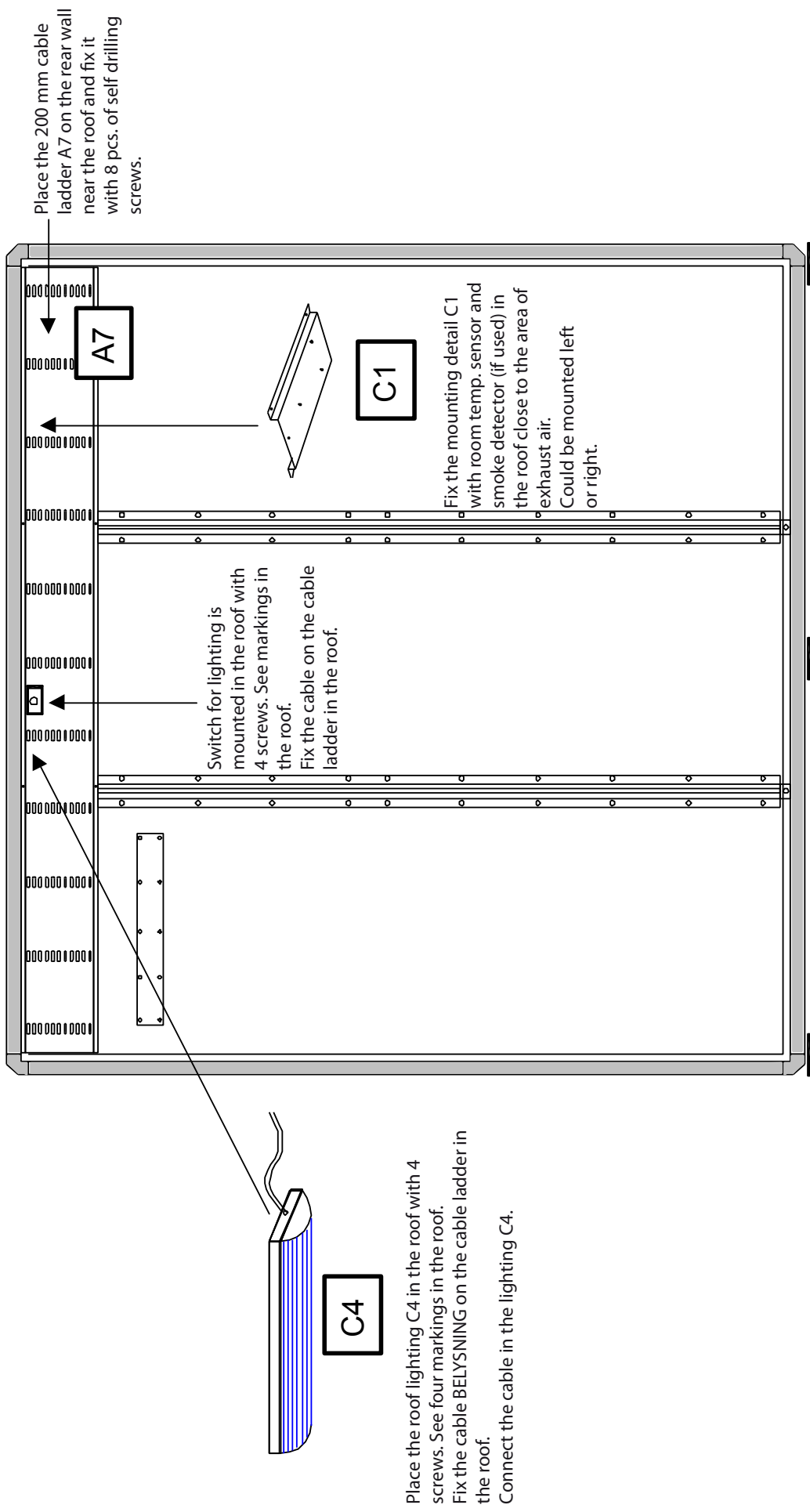

Install cooling

Alternative mounting of CoolRack, see manual for CoolRack KS

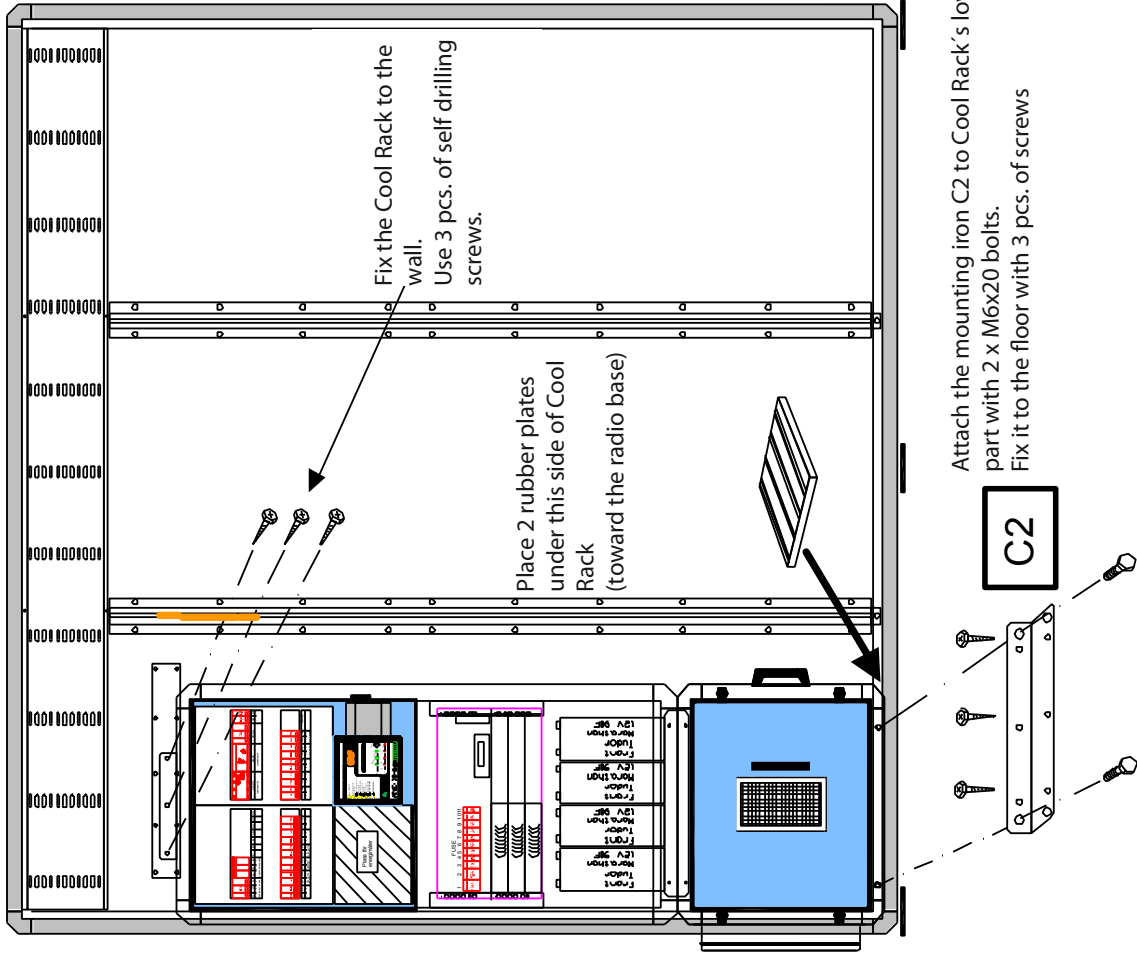

Install covers

Place the aluminium profile A2 through the 7 mm holes in roof and floor profiles. Fix them with the bolts. This profile can be removed if full door opening is needed.

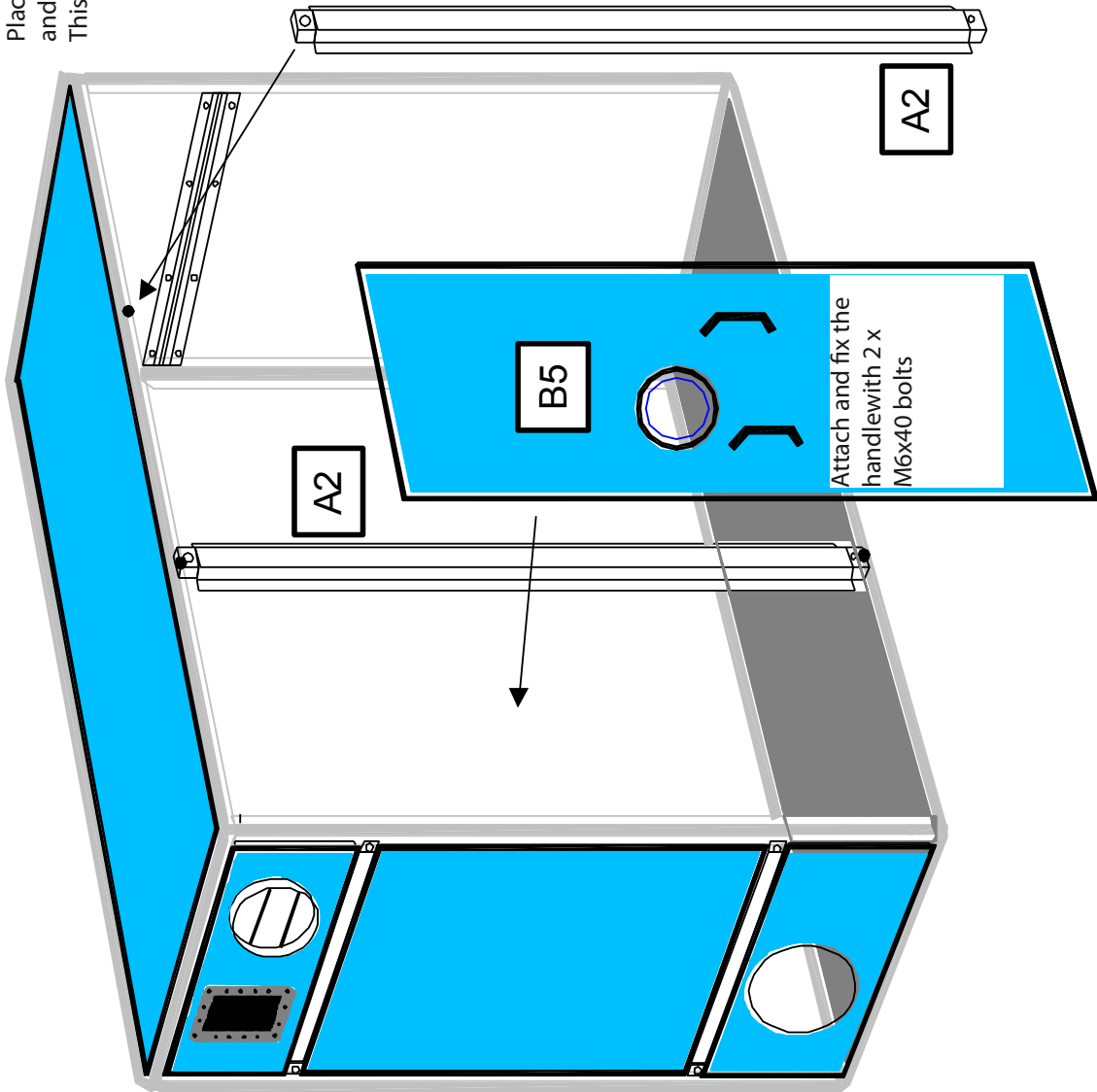

Always place the door B6 in the middle.

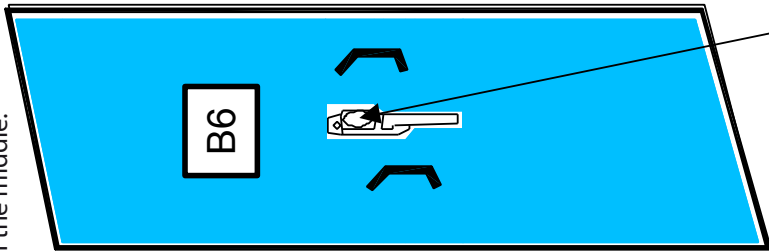
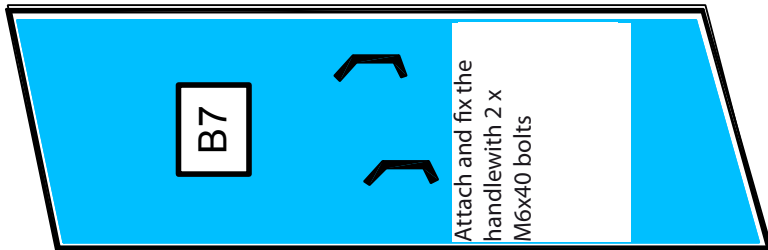

Complete with cylinder lock. Use the attached one-way screws.

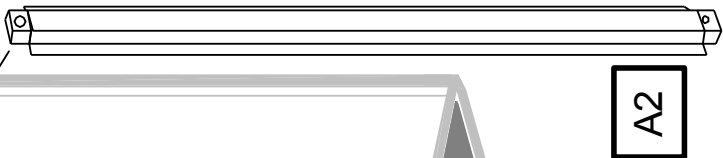

A2

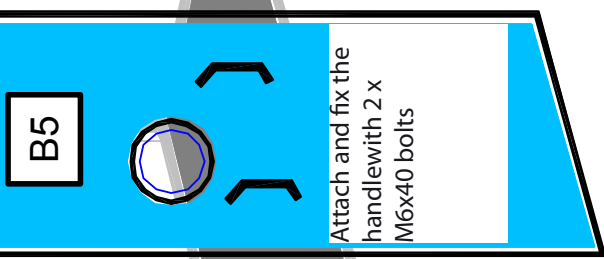

B5

B6

B7

Install cables

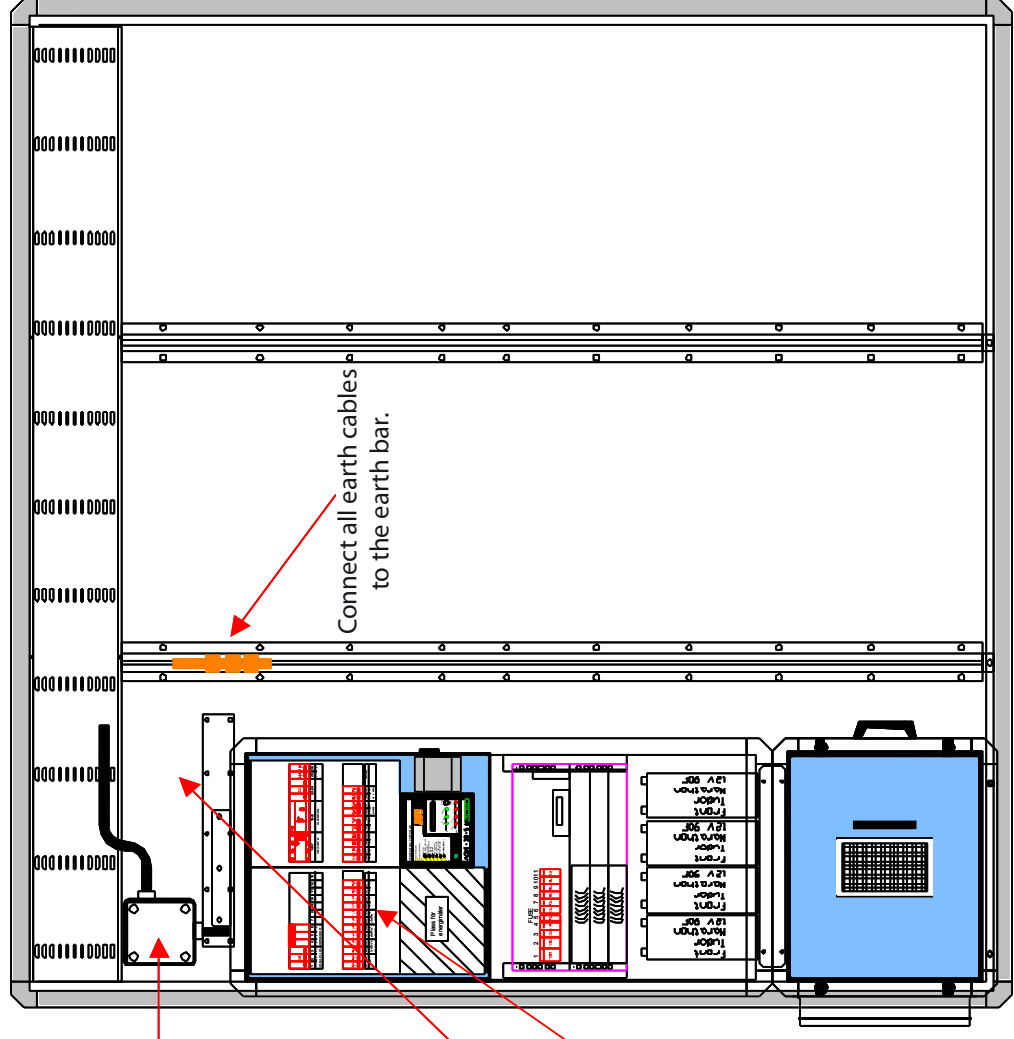

Place and fix the cable box for main power above CoolRack.

Fix the cable for lighting and switch for lighting on the cable ladder in the roof. Place them together with cables for room temp. sensor, smoke detector (if used) and exhaust air damper motor and allow them to come down into the CoolRack. Fix the cables inside the CoolRack.

Notice that intruder alarm (open door) can be connected to terminal 4-5 inside the 400 V module box. The alarm contact breaks at open door = NC.

Connect all earth cables
to the earth bar.

Finalizing

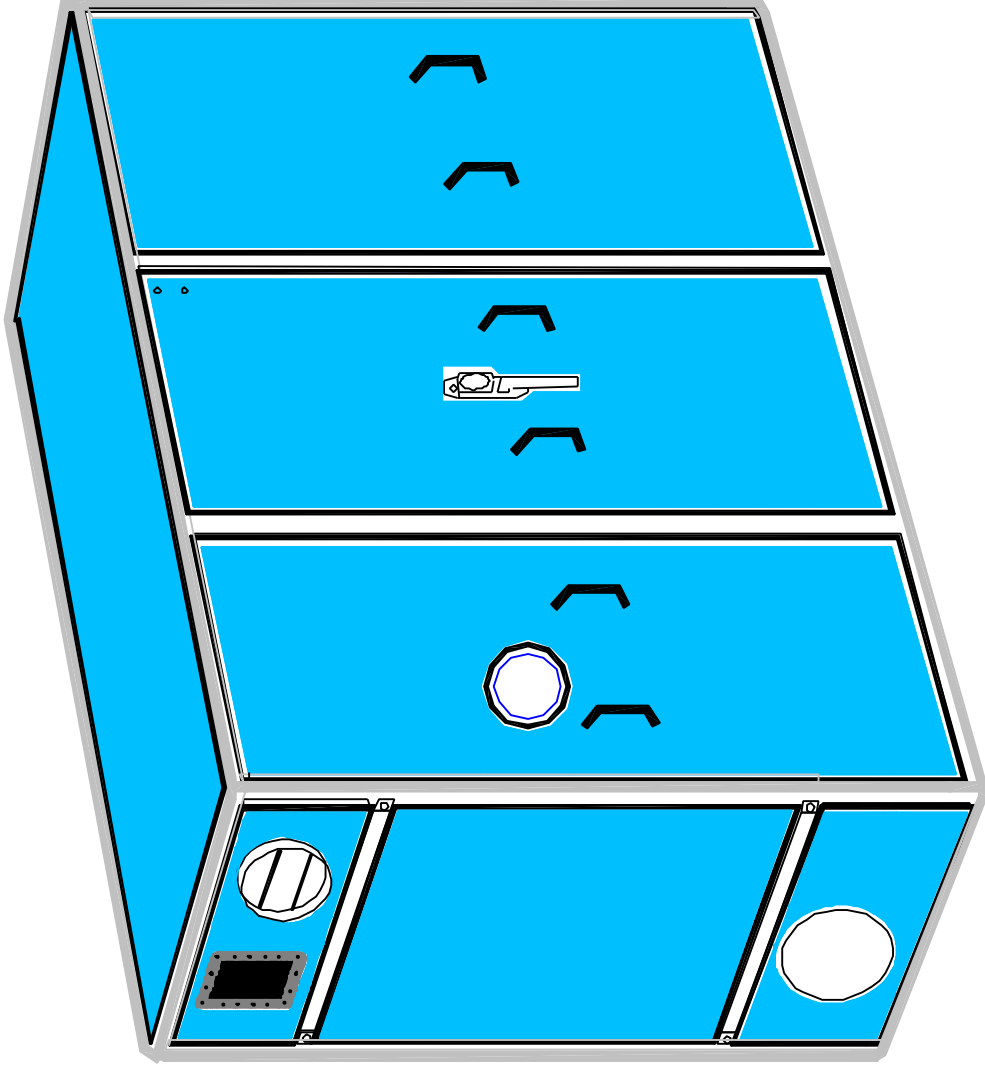

Before You leave the site and IS-1/2 please remove the thin plastic protection on all blue walls and doors. We recommend that You, at least, remove the plastic protection from the doors because of risk for electrostatic discharge.

IS-1



IS-2



se

Innehåll

Tekniska data	2
IS-1 Mått, framsidan	3
IS-2 Mått, framsidan	4
IS -1/2 Mått, vänster sida.....	5
IS-1/2 Mått, höger sida	6
Alternativ 1	7
Alternativ 2	8
Alternativ 3	9
Alternativ 4	10
Förpackningen	11
Materialspec.....	13
Montering	20

Montera golv.....	21
Montera hörnstolpe	22
Montera tak	24
Montera bagväggarna.....	25
Montera sidoluckor, Alternativ 1.....	26
Montera sidoluckor, Alternativ 2.....	27
Montera sidoluckor, Alternativ 3.....	28
Montera sidoluckor, Alternativ 4.....	29
montera kabelränna.....	30
Montera coolrack.....	31
Montera dörrar.....	32
Innan du går	34

Tekniska data

Technical data	
Flat pac delivery	Calculated assembling time: 2 mens work approximate 3 hours
Weight	IS-1: 110 kg IS-2: 250 kg + pallet 20 kg
Frame	Aluminium profiles
Floor	27 mm hard plywood with antistatic rubberized surface
Walls & roof	Sandwich construction with side and end panels of double-walled galvanized sheet-metal. Blue lacquered exterior. A layer of 25 mm polyurethane insulation between panels
U-value	0,96 W/m ² /°C
Outside measurement	IS-1: 1580x850x2250 mm (WxDxH) IS-2: 2350x850x2250 mm (WxDxH)
Inside measurement (wall to wall)	IS-1: 1530x800x2200 mm (WxDxH) IS-2: 2290x790x2190 mm (WxDxH)
Door opening	2230x2130 mm (WxH)
Door lock entrance	4-way espagnolette and ASSA key
Door lock service door	Push lock in upper position, 2 sliding safety catch
Air intake	Ø 400 mm
Exhaust air	Ø 315 mm via motorised damper
Fix points for CoolRack KS-1 RT 3	2 st (up and down)

SE

ELECTRICAL CABLING WAY

Type: One 200 mm sheet metal cable ladder on the rear wall and one 100 mm sheet metal cable ladder in the roof.

FEEDER

Type: Roxtec Comlite 6-18

EXHAUST AIR DAMPER

Damper, type: SP315311, G-profile
Damper actuator: LM24 (24 VDC)

LIGHTING

Type: 230 V, 2x18 W luminance tube

IS-1 Mått, framsidan

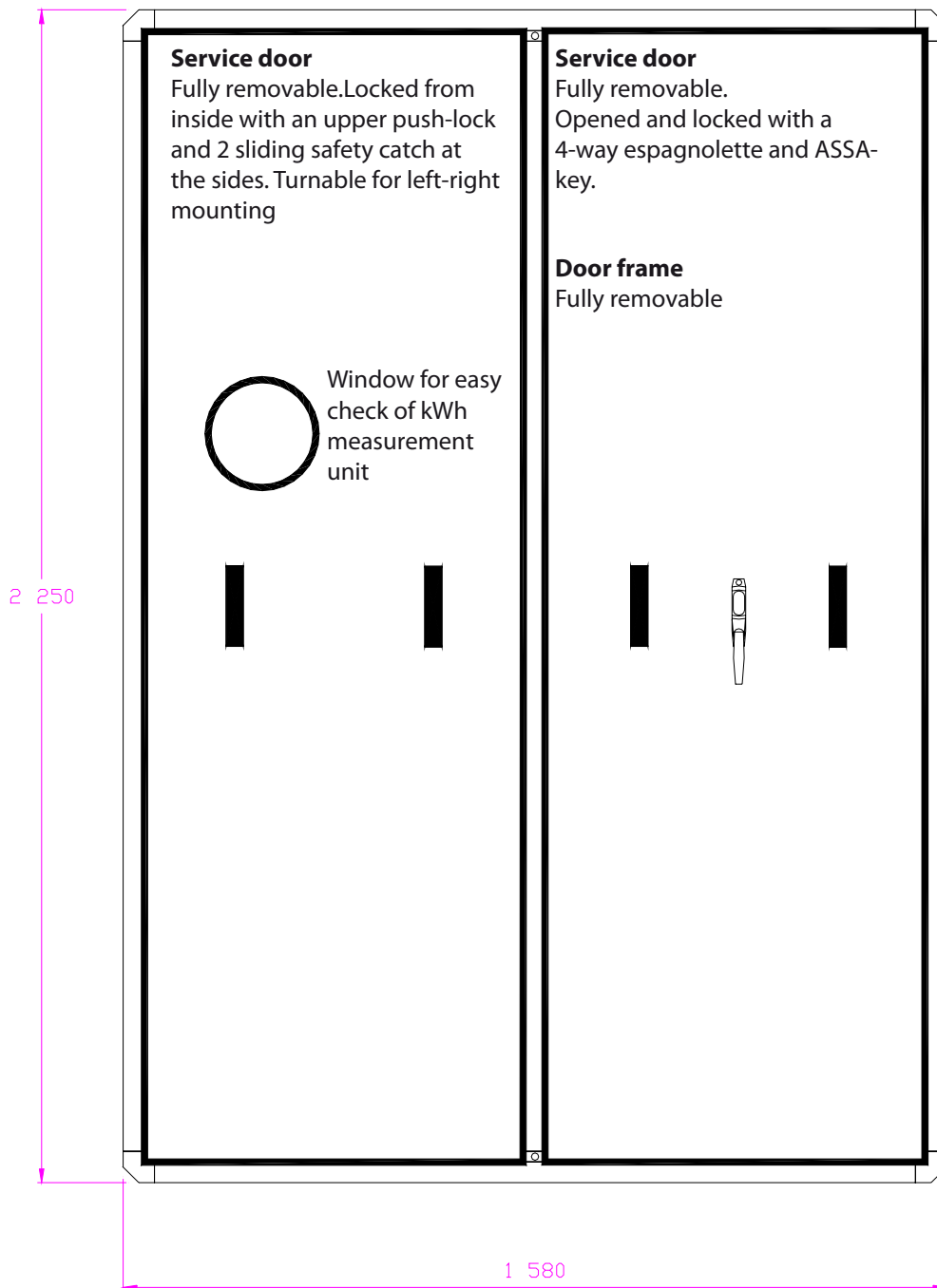

IS-2 Mått, framsidan

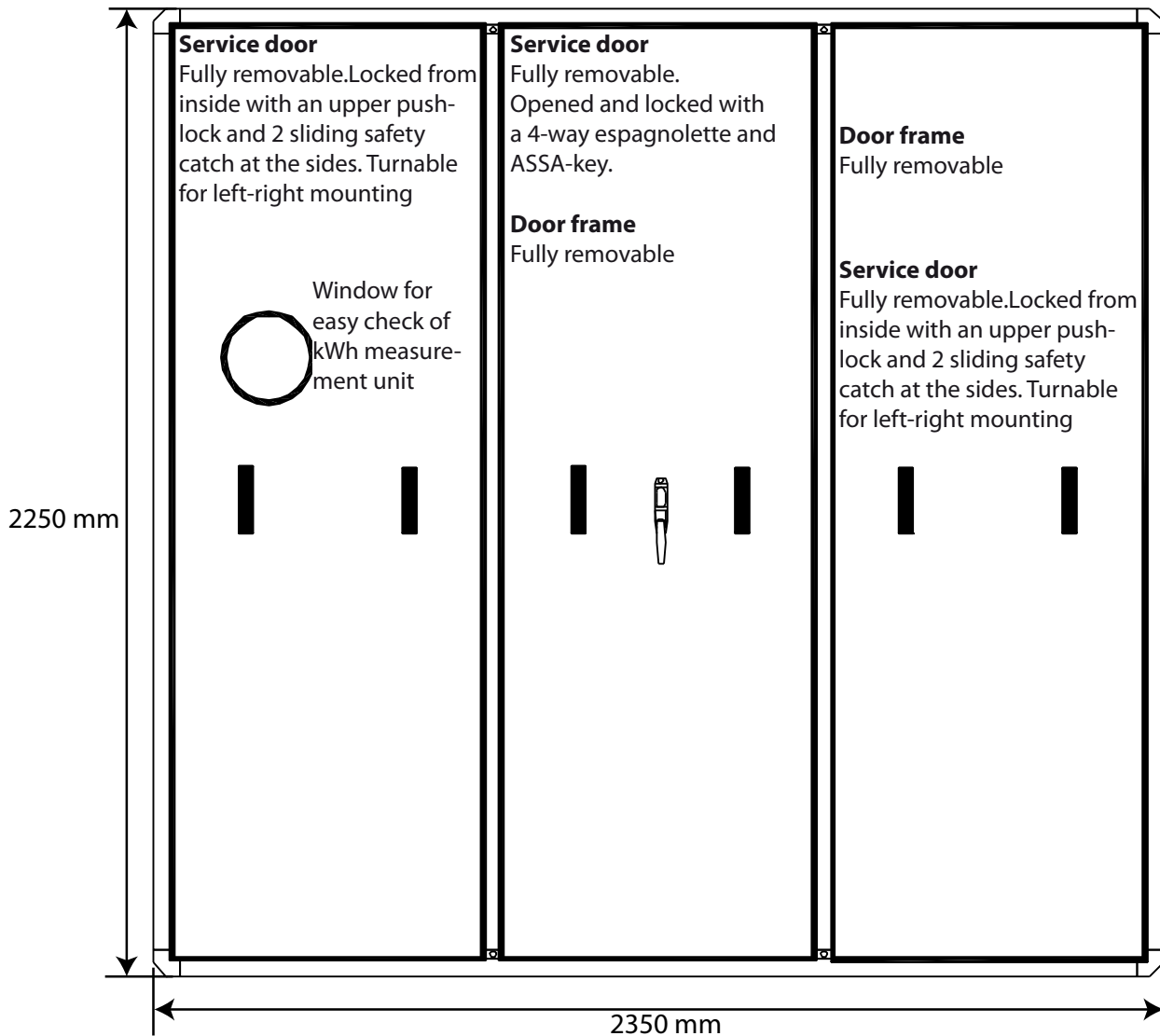

IS -1/2 Mått, vänster sida

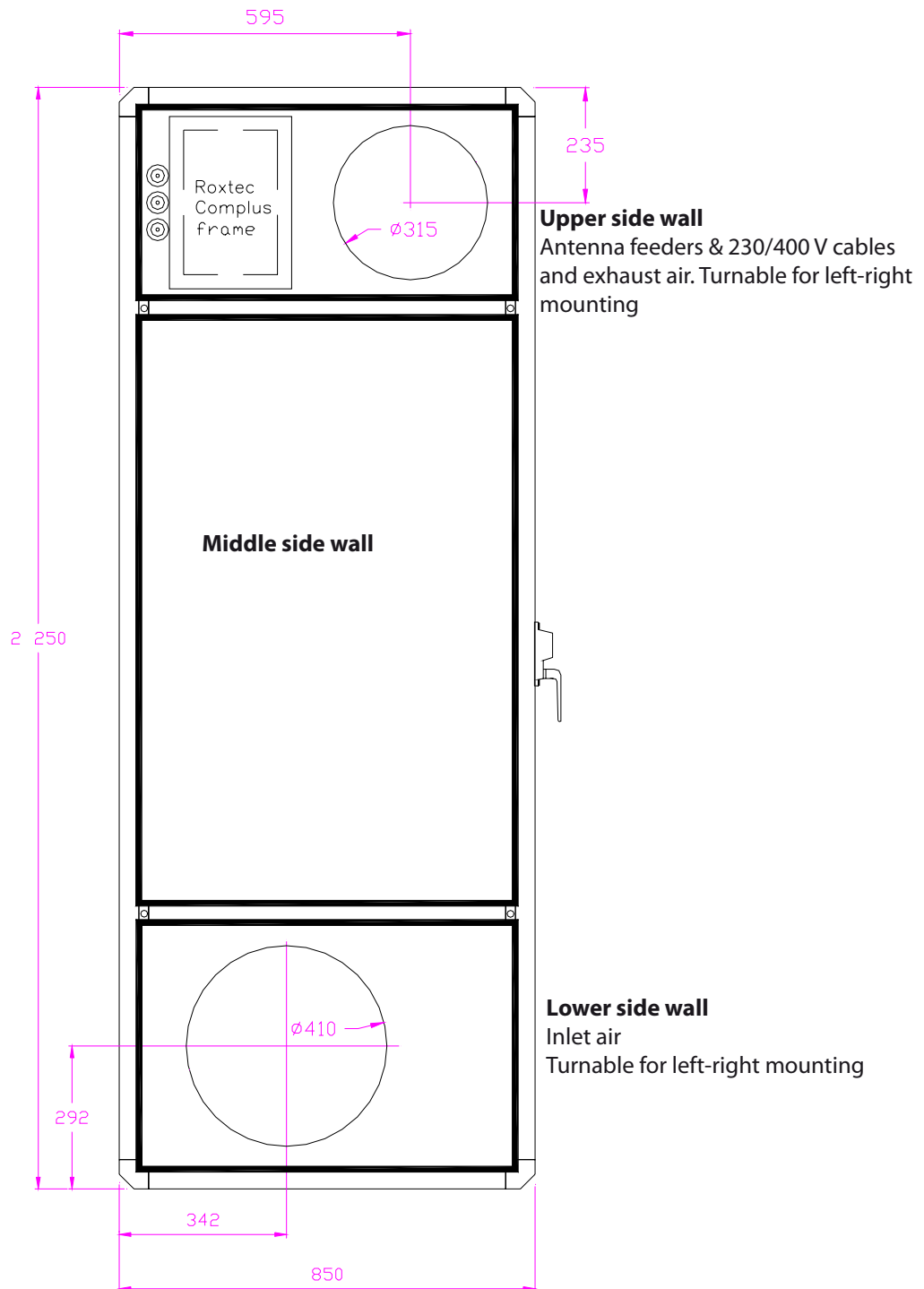

IS-1/2 Mått, höger sida

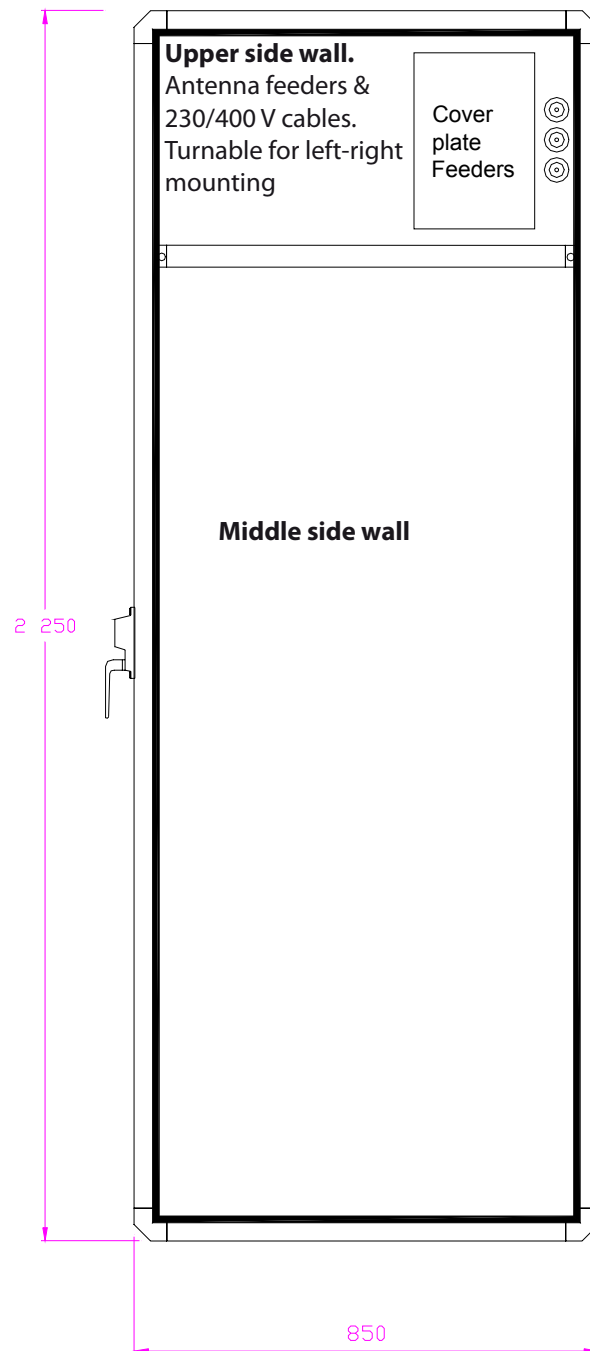

Alternativ 1

Inlet air & exhaust air from the left.
Antenna feeders from left or right.
230/400 V cables from left or right.

IS-1

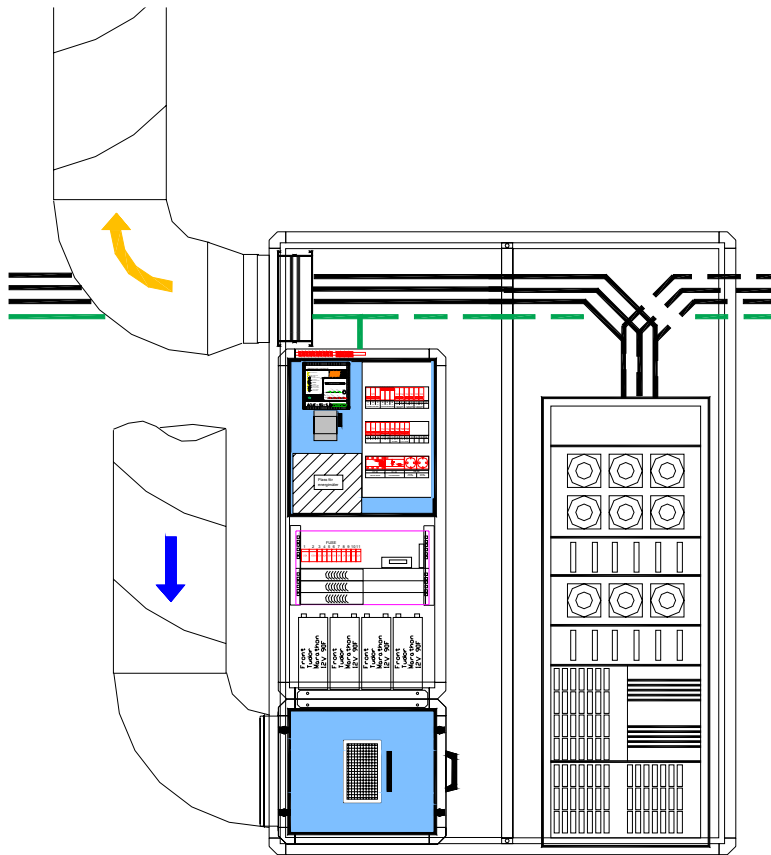

IS-2

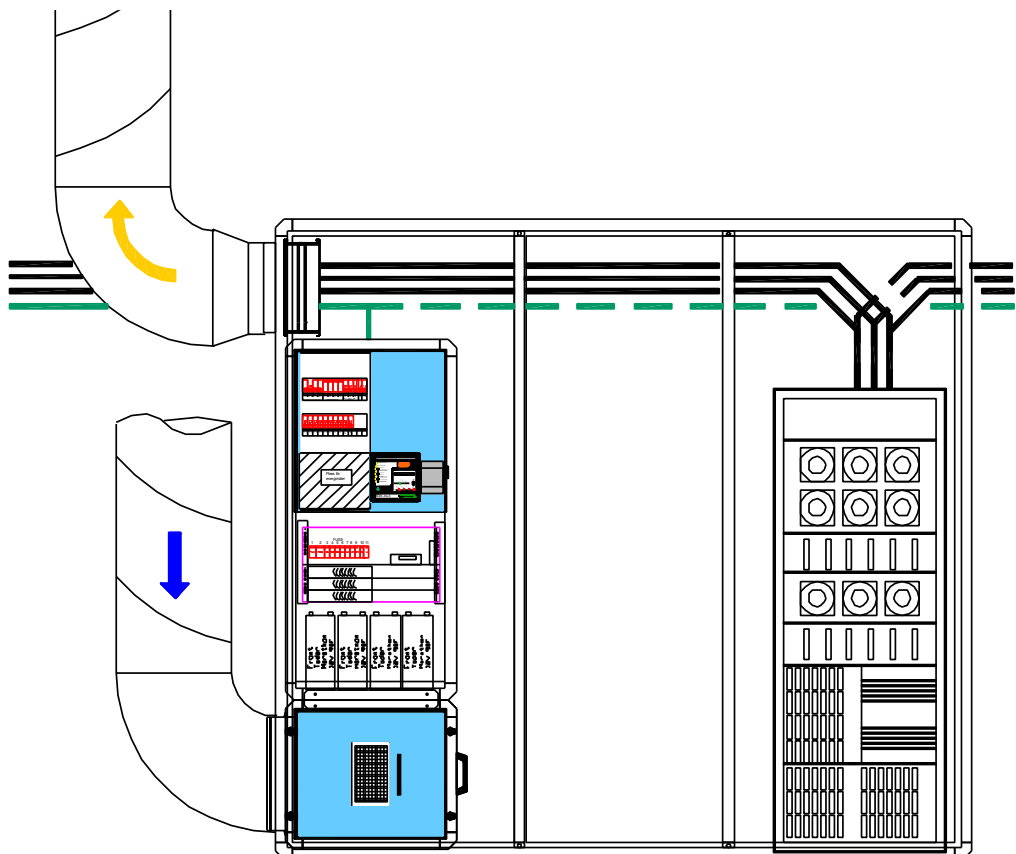

se

Alternativ 2

Inlet air from the left.

Exhaust air from the right.

Antenna feeders from left or right.

230/400 V cables from left or right.

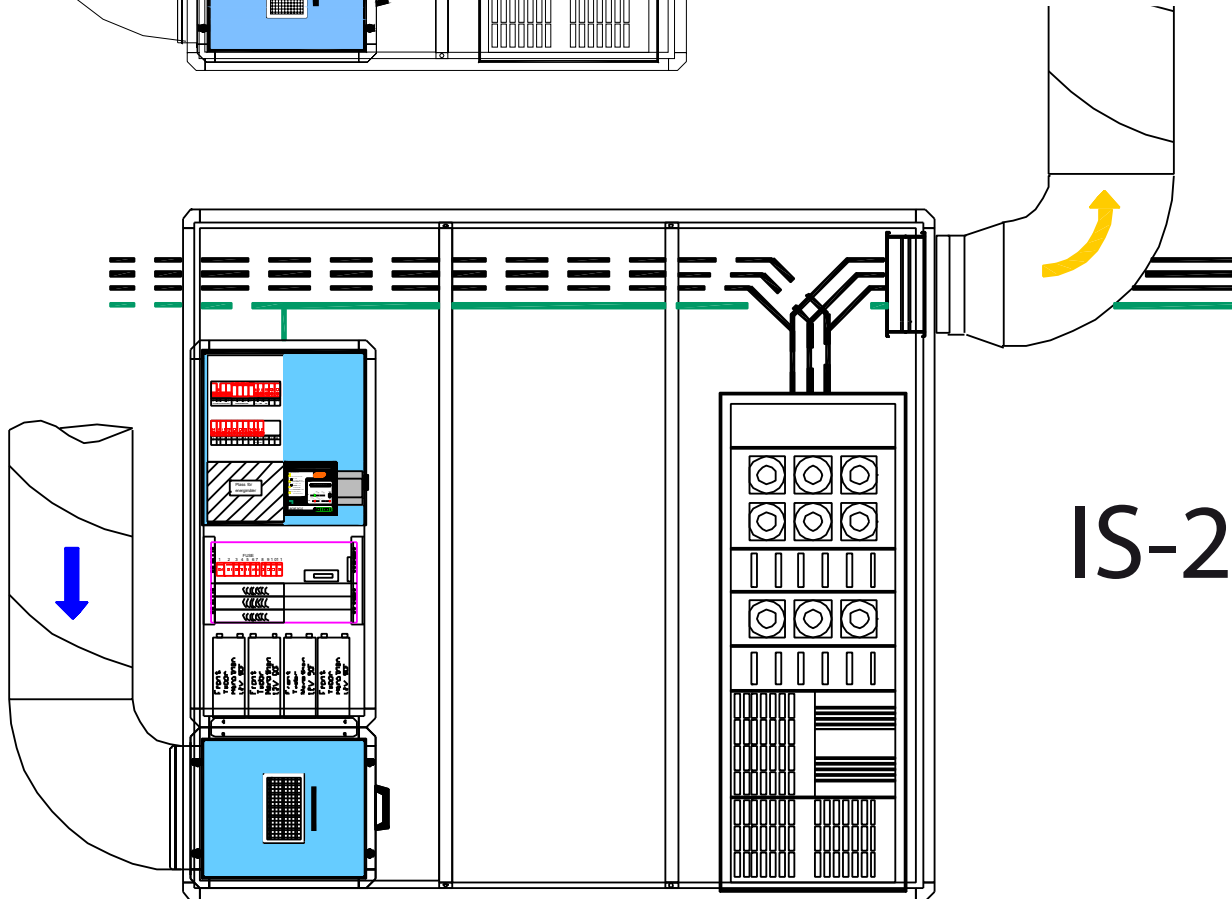
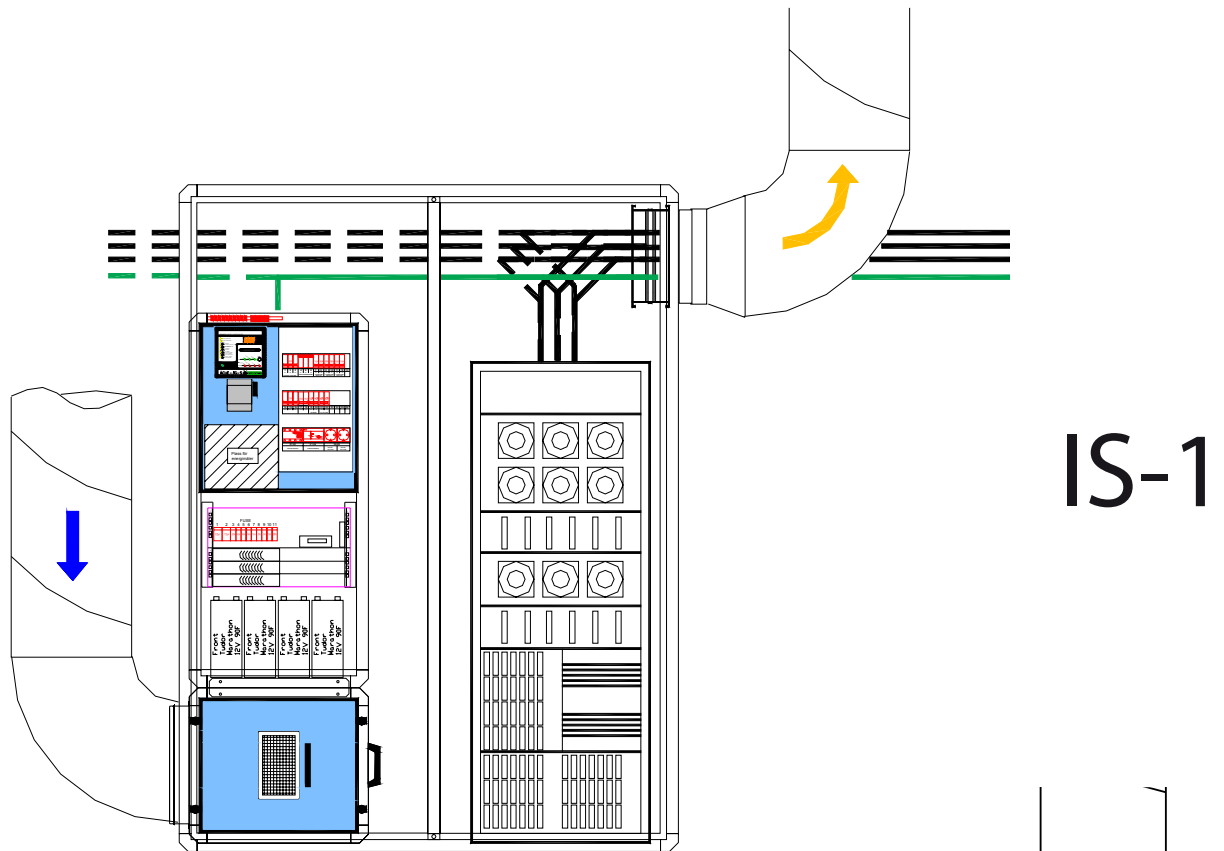

se

Alternativ 3

Inlet air & exhaust air from the right.
Antenna feeders from left or right.
230/400 V cables from left or right..

IS-1

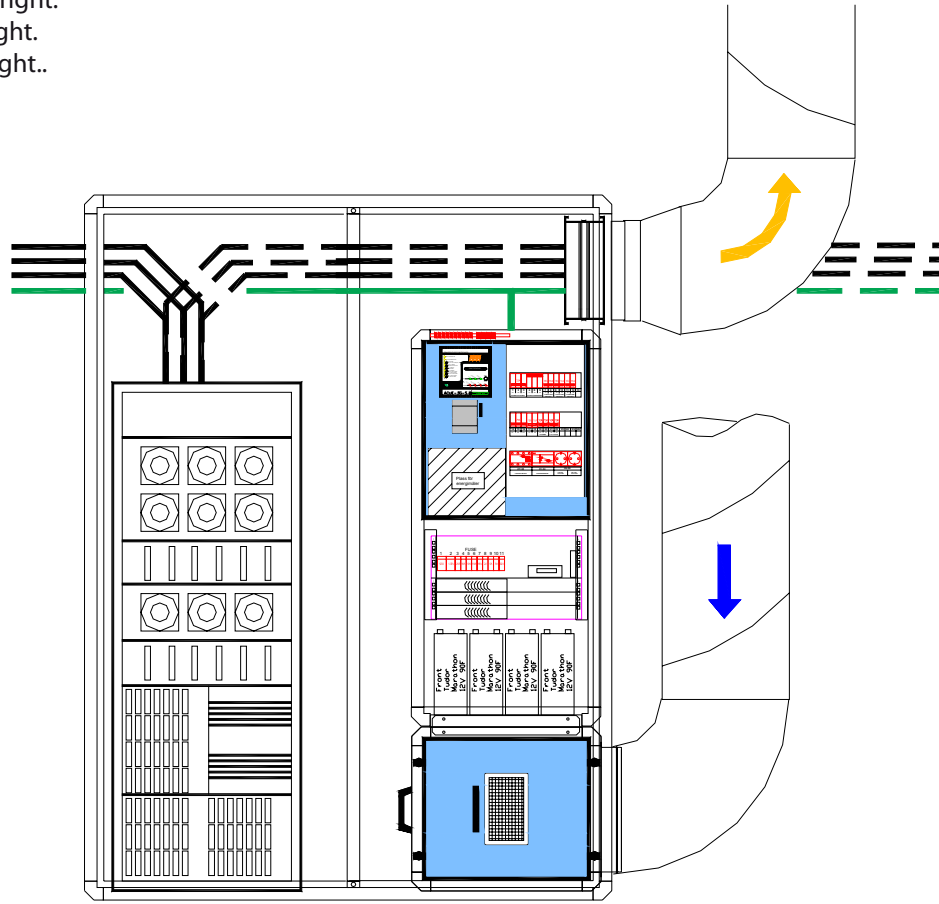

IS-2

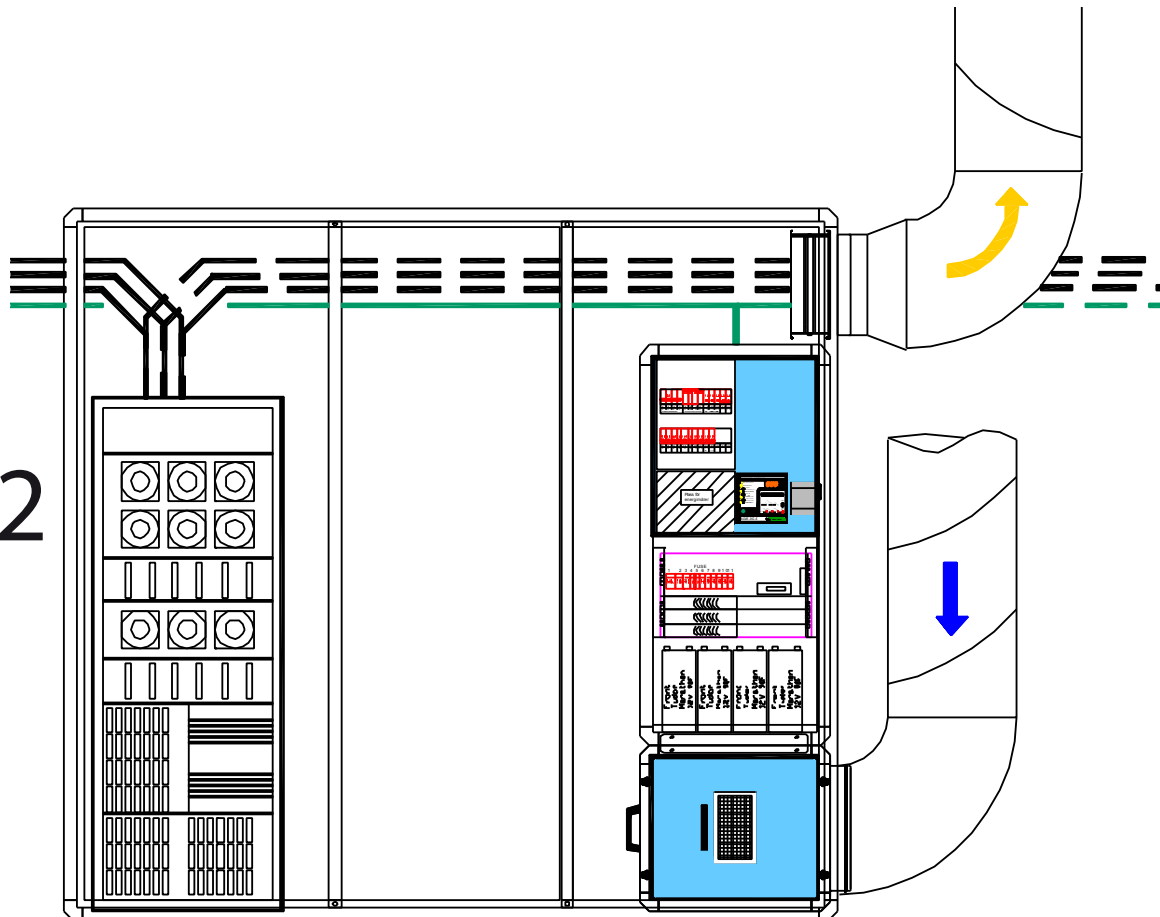

Alternativ 4

Inlet air from the right. Exhaust air from the left.
Antenna feeders from left or right.
230/400 V cables from left or right.

IS-1

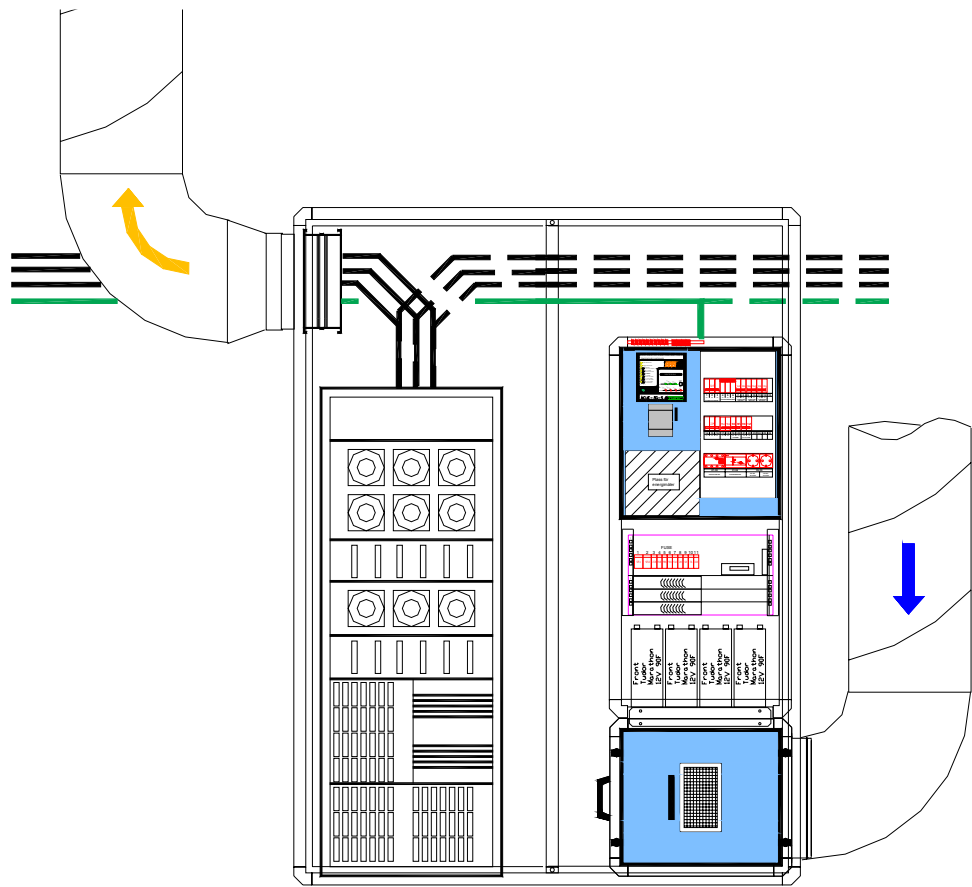

IS-2

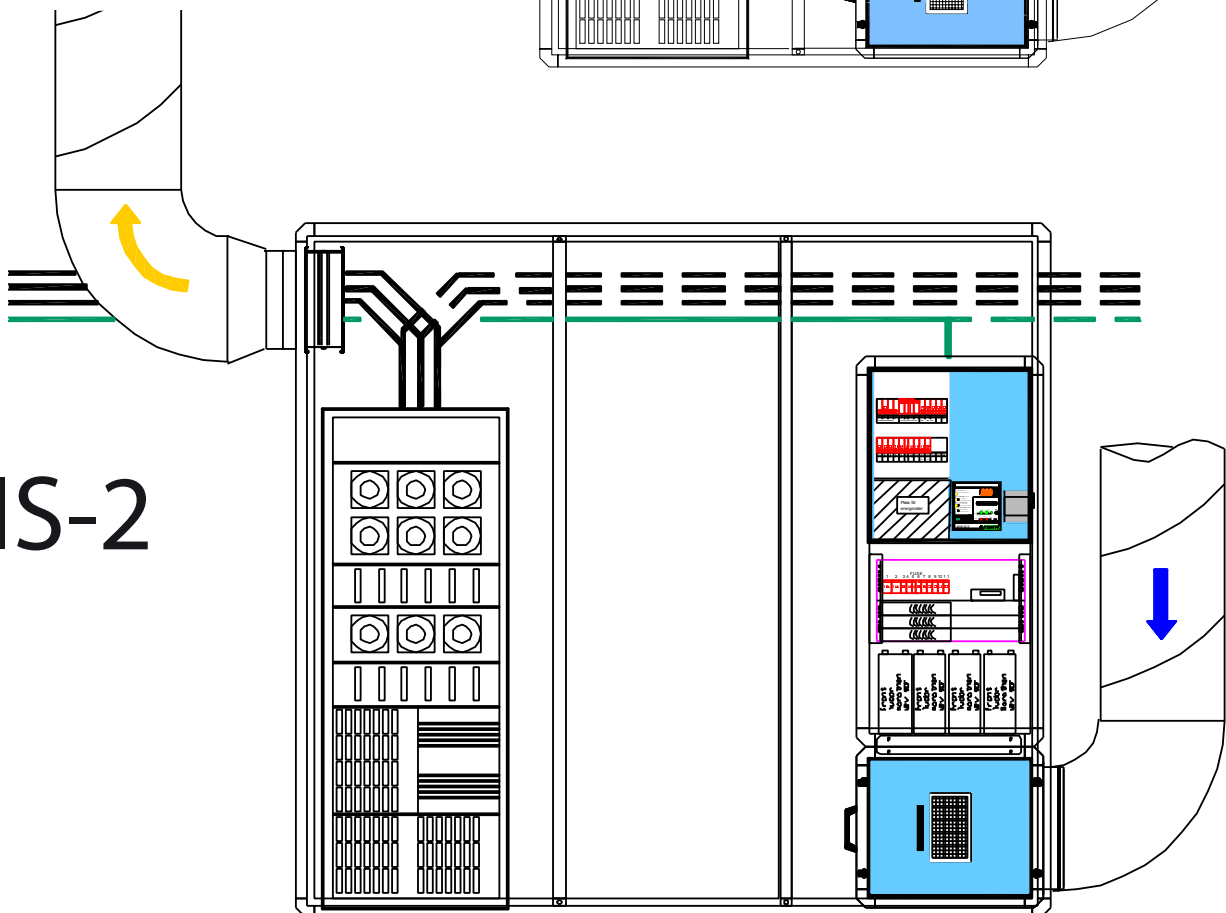

Förpackningen







This four corners made of aluminium are only for the package and are not meant to be used in the building .

Montageanleitung

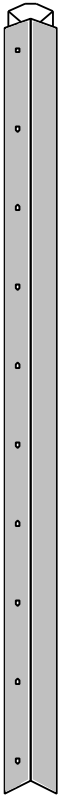
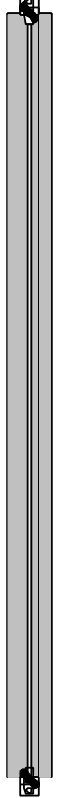

IS-1 byggs precis som IS-2 fast med den skillnaden att den bara har två dörrar istället för tre. Märkningarna är lika.

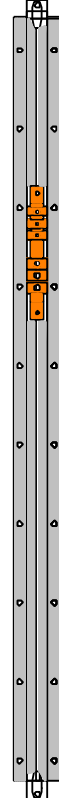
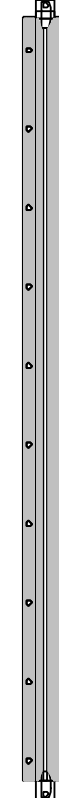
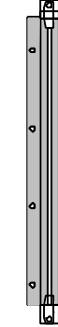
Materialspec.

Profil	Beteckning	Förklaring
	A1	Främre hörnstolpe, 2 st Hålraden vändes mot kortsidorna av sheltern. <u>Inga hål mot entrésidan.</u>
	A2	Främre dörrstolpar, 2 st Styrstiftet placeras i förborrat 7 mm hål i framkant på tak och gol Låses med vred.
	A3	Bakre hörnstolpe, 2 st
	A4	Bakre dörrstolpe med jordskena, 1 st Placeras efter första bakväggen, närmast Cool Rack, med jordskenan uppåt. Fixeras med skruv mot bakväggarna..
	A5	Bakre dörrstolpe, 1st Placeras mellan bakväggarna och fixeras med skruv mot bakväggarna.
	A6	Horisontella avbärare på sidorna, 2 + 1 st Placeras mellan sidoväggarna beroende på montagealternativ 1 Fixeras med skruv mot sidväggarna.
	A7	Kabelstege, 1 st Placeras på bakväggen upp mot takkanten. Fixeras med 8 st självborrande skruv.

Materialspec.

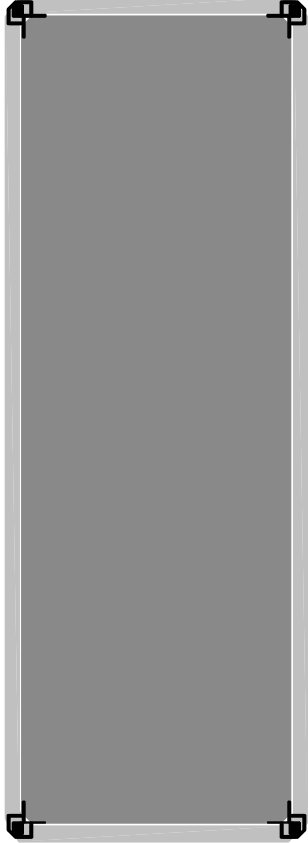
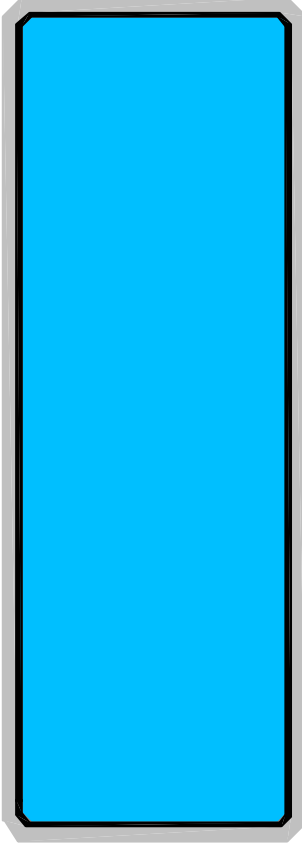
Paneler	Beteckning	Förklaring
	B1	Golv, 1 st Placeras på avvägt underlag med minst 6 st gummiplattor som vibrationsunderlag. Se till att långsidan med 2 st 7 mm hål placeras där dörrpartiet ska vara.
	B2	Tak, 1 st Levereras med kabelränna och eventuell brytare för belysning. Se till att långsidan med 2 st 7 mm hål placeras där dörrpartiet ska vara.

Materialspec.

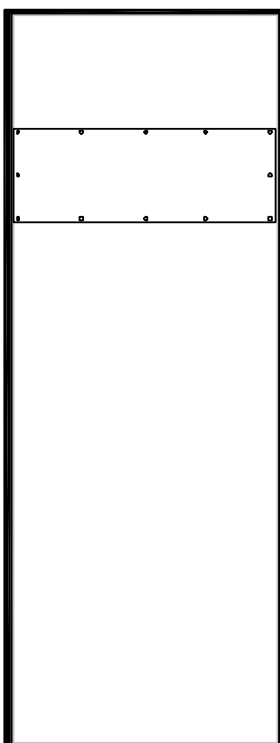
Paneler	Beteckning	Förklaring
	B3	Bakvägg, 3 st Montageplattan är montageyta för Cool Rack och radiobasens övre väggfäste.

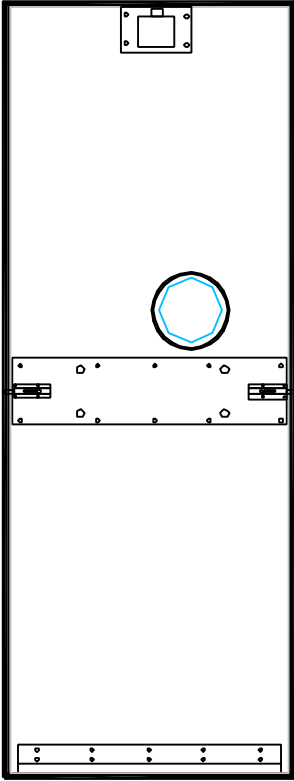
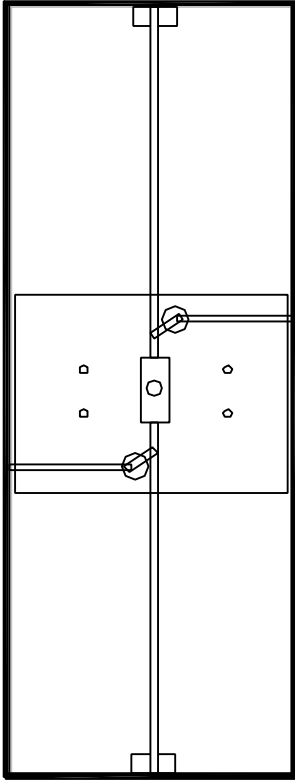
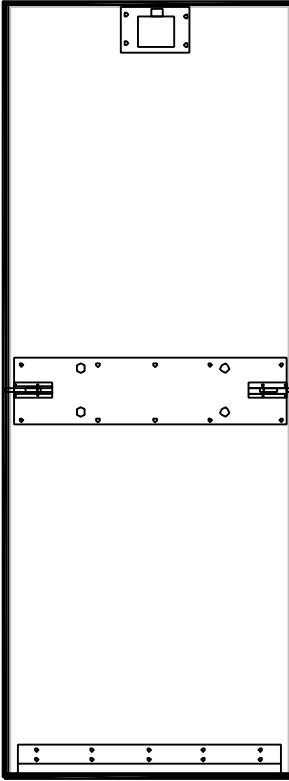

Materialspec.

Paneler	Beteckning	Förklaring
	B5	Dörr med fönster, 1 st Placeras framför stativ Cool Rack. Fönster (option) till avläsning av elmätare. Snäpplås uppåt.
	B6	Dörr med lås, 1 st Placeras i mitten. Förses med låskolv.
	B7	Dörr, 1 st Snäpplås uppåt.

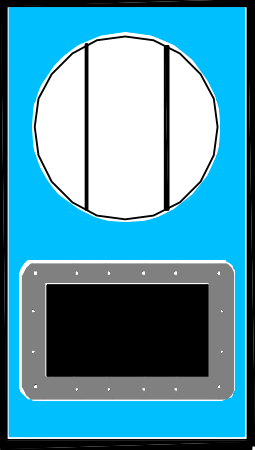
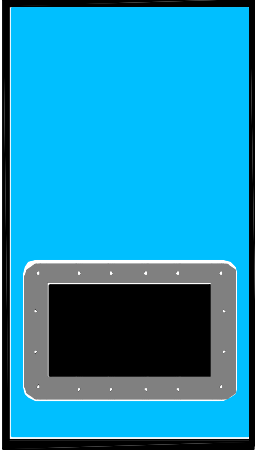
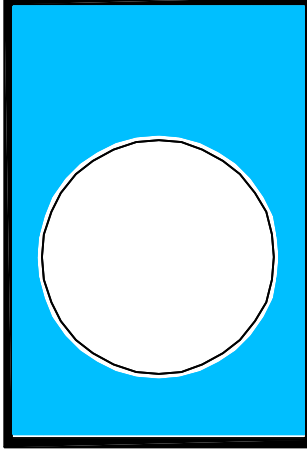



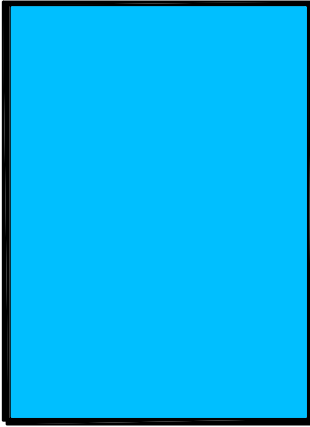

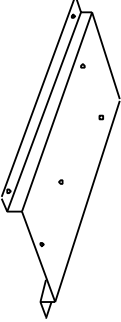

Materialspec.

Paneler	Beteckning	Förklaring
	B8	Övre sidolucka med spjäll och Roxtec, 1 st Placeras där avluft sker. Kabel in-ut via Roxtec Comlite 6/18
	B9	Övre sidolucka med Roxtec, 1 st Placeras på andra sidovägg för alternativ kabel in-ut via Roxtec Comlite 6/18.
	B10	Intagslucka, 1 st Placeras där luffintag ska bli. Vändbar för vänster eller höger sida.

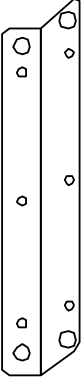
Materialspec.

Paneler	Beteckning	Förklaring
	B11	Sidolucka, 1 st Utfyllnad mellan luckorna B8 – B10
	B12	Sidolucka, 1 st Utfyllnad mellan luckorna B8 – B10

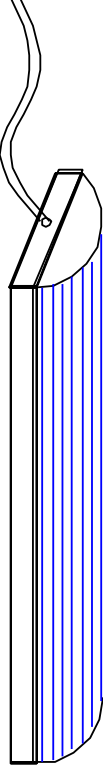
Materialspec.

Övriga detaljer	Beteckning	Förklaring
		Montageplåt med rumsgivare & eventuell rökdetektor, 1 st Placeras i tak i <u>närheten av avluft</u> .
		Fästvinkel för stativ Cool Rack, 2 st OBS! En är monterad på Cool Rack vid leverans. Den andra skruvas med 2 st M6 skruv i fläktenhetens underdel, i framkant. Fixeras sedan i golvet med 3 st skruv.
		Gummimatta 100x100 mm, 12 st. Lägges under golvprofilen för utjämning och som ljudabsorbent. Placera 6-8 st under golvet. Viktigt! Lägg 2 st gummimatta under stativ Cool Rack's främre och bakre hörn (mot radiobasen) vid inplacering av stativet, för att utjämna höjdskillnaden vid golvet's aluminiumprofiler.
		Takbelysning, 1 st Placeras i taket i anvisade hål med 4 st skruv. Kabel BELYSNING fästes på kabelrännan och anslutes i lampa.

Montering

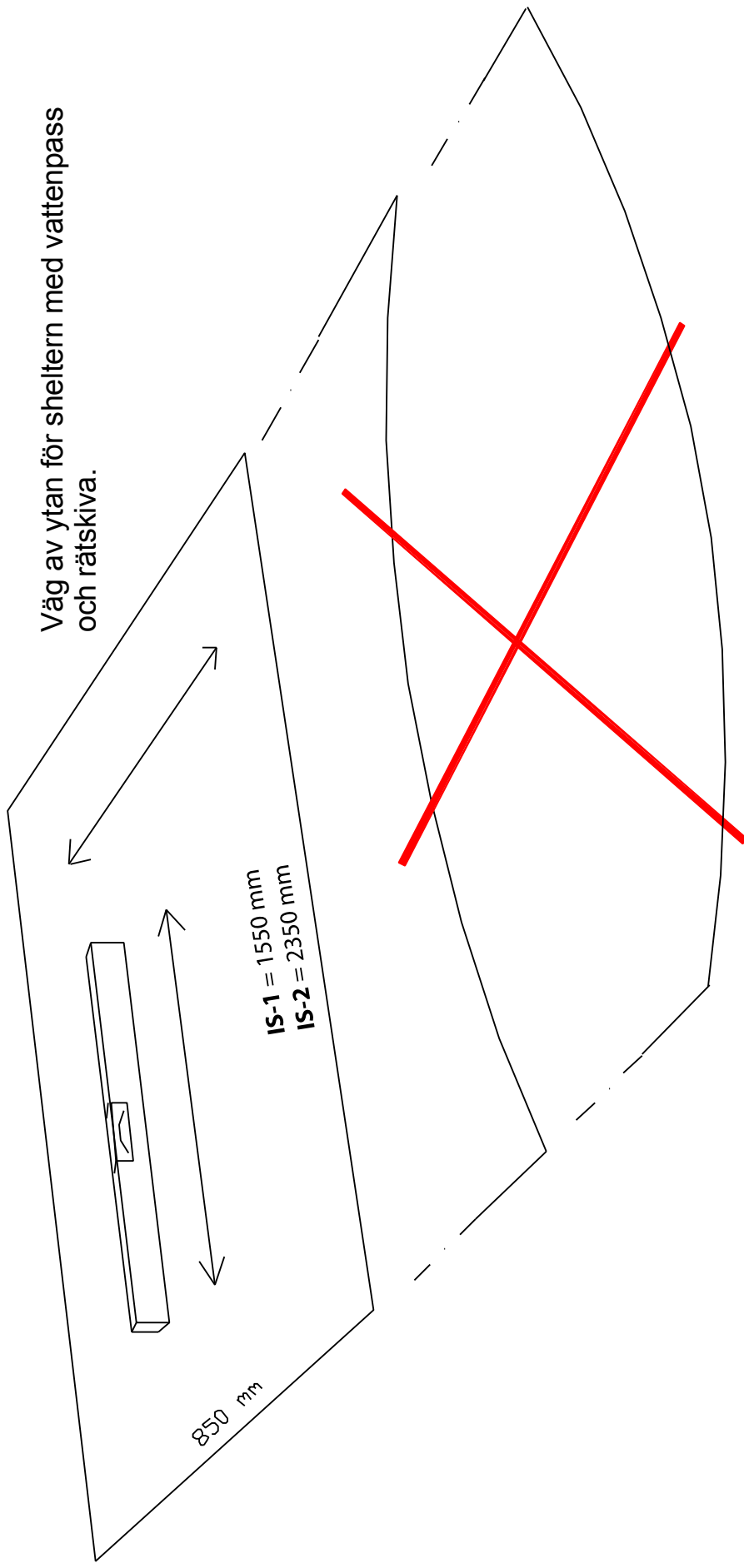

Montera golv

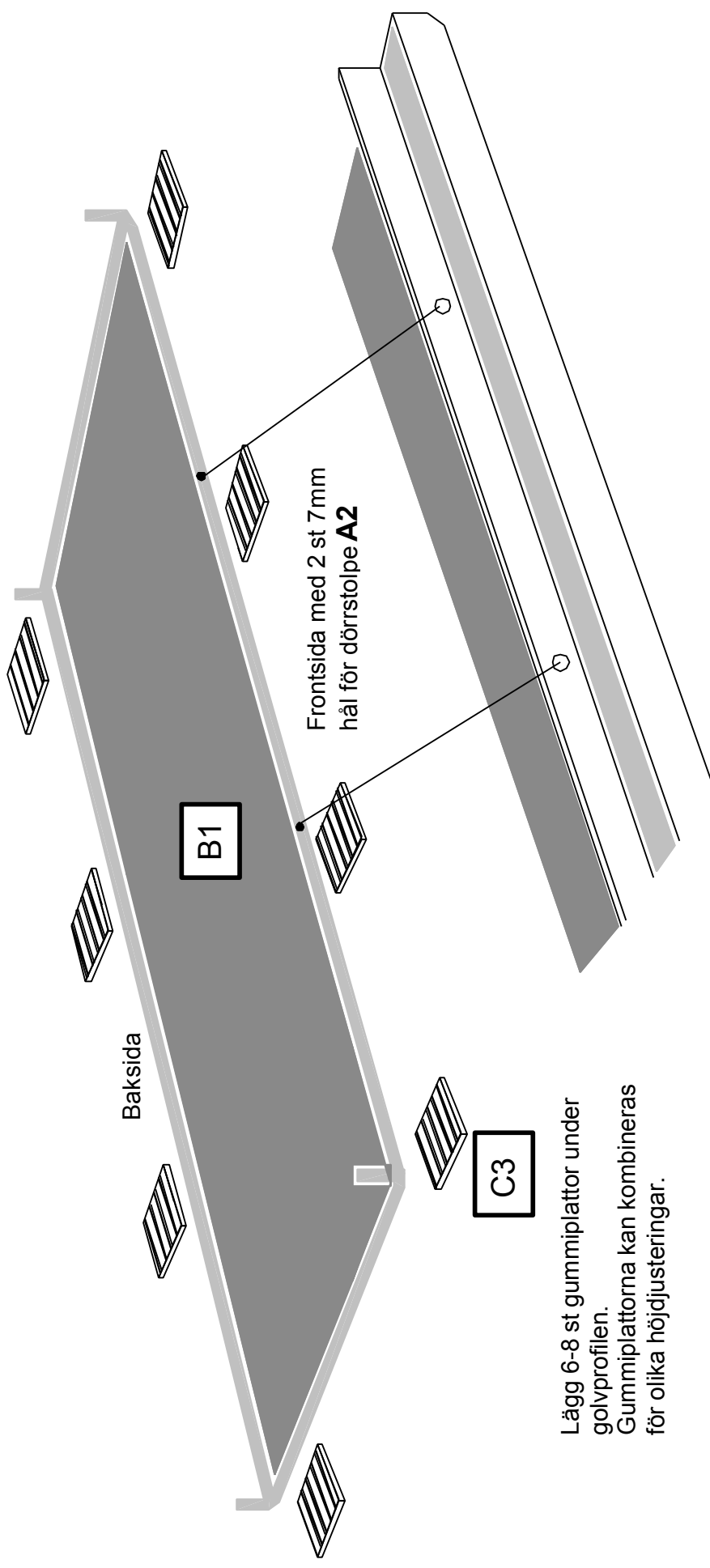

Montera hörnstolpe

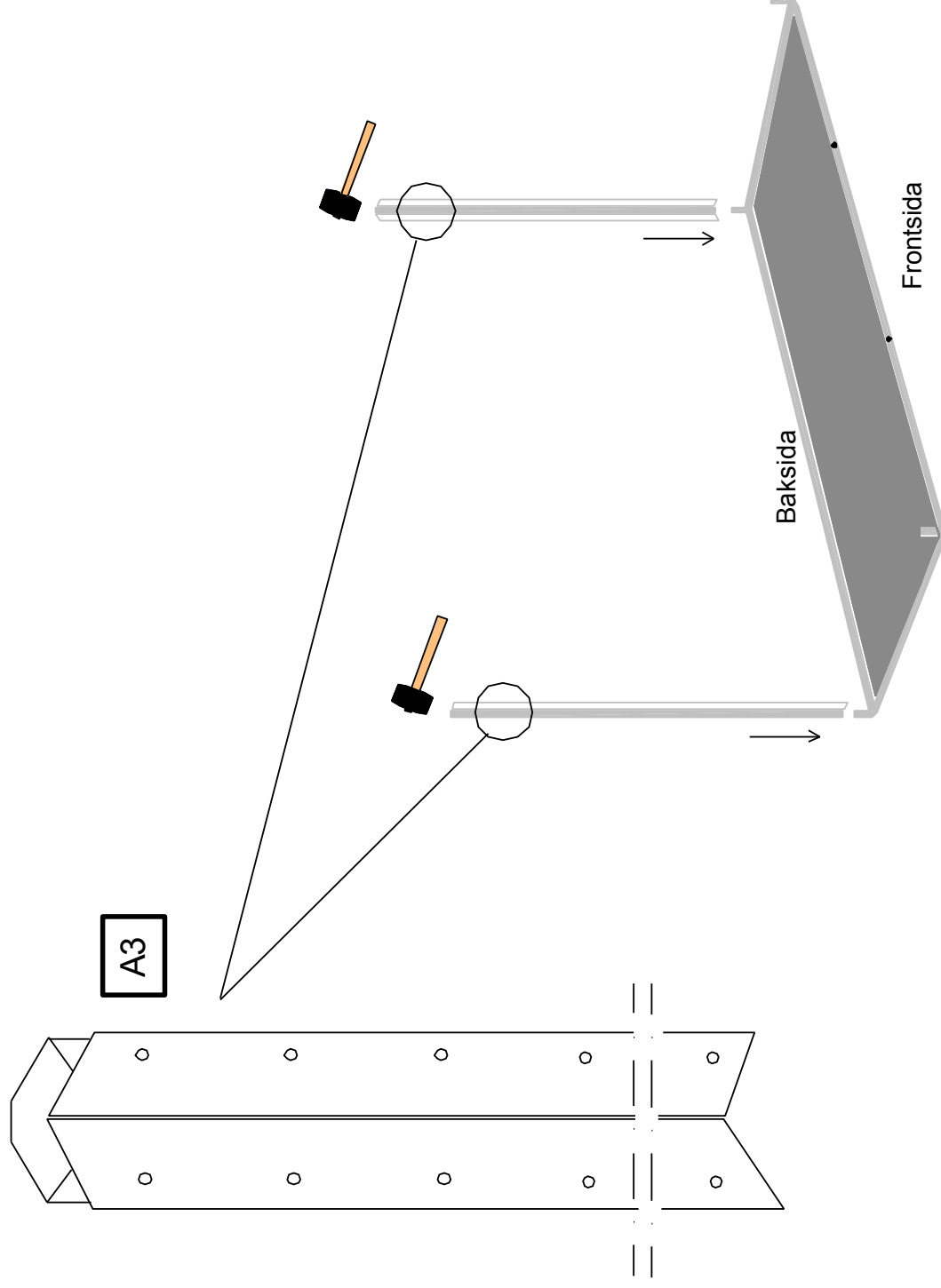

Montera hörnstolpe

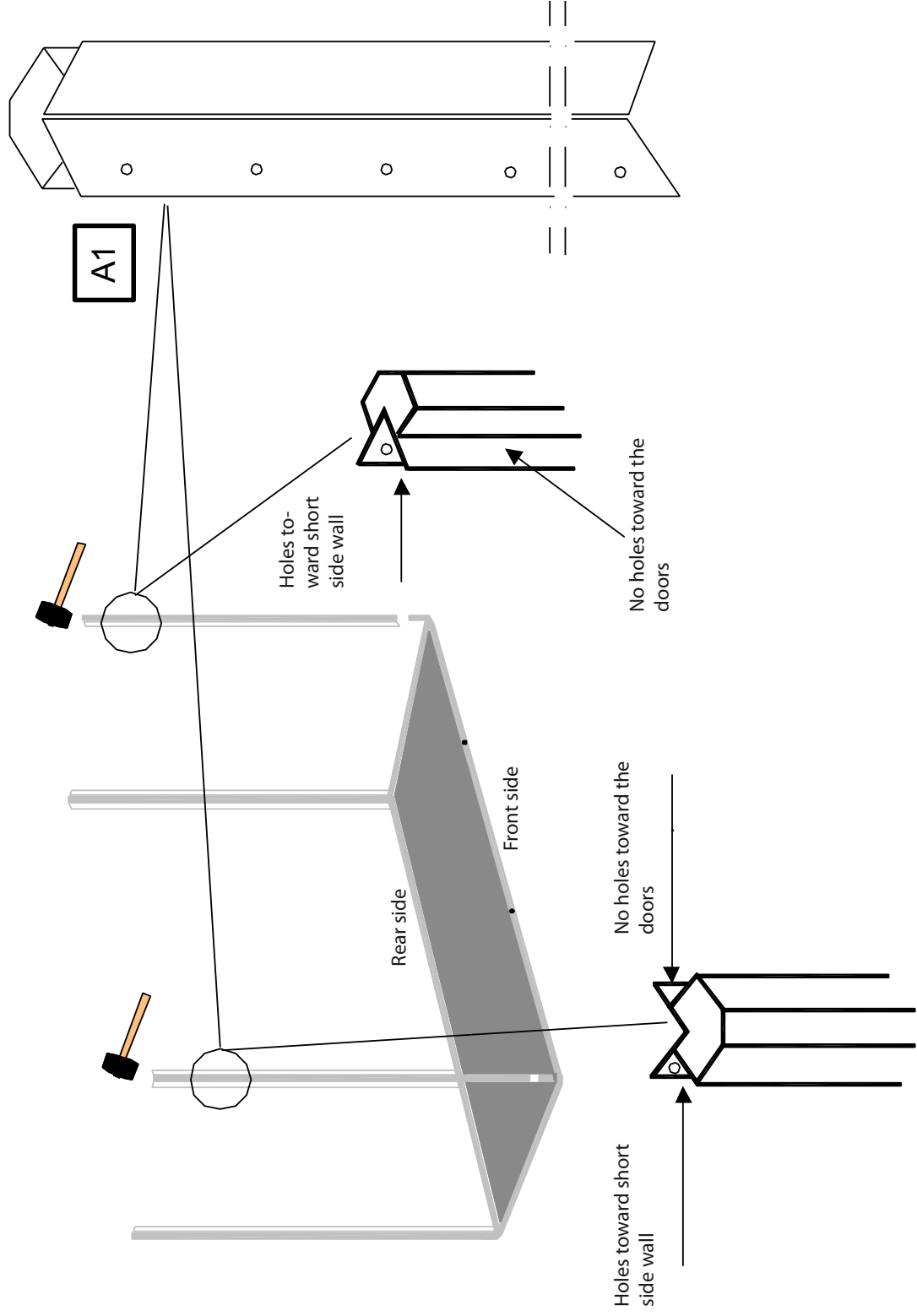

Montera tak

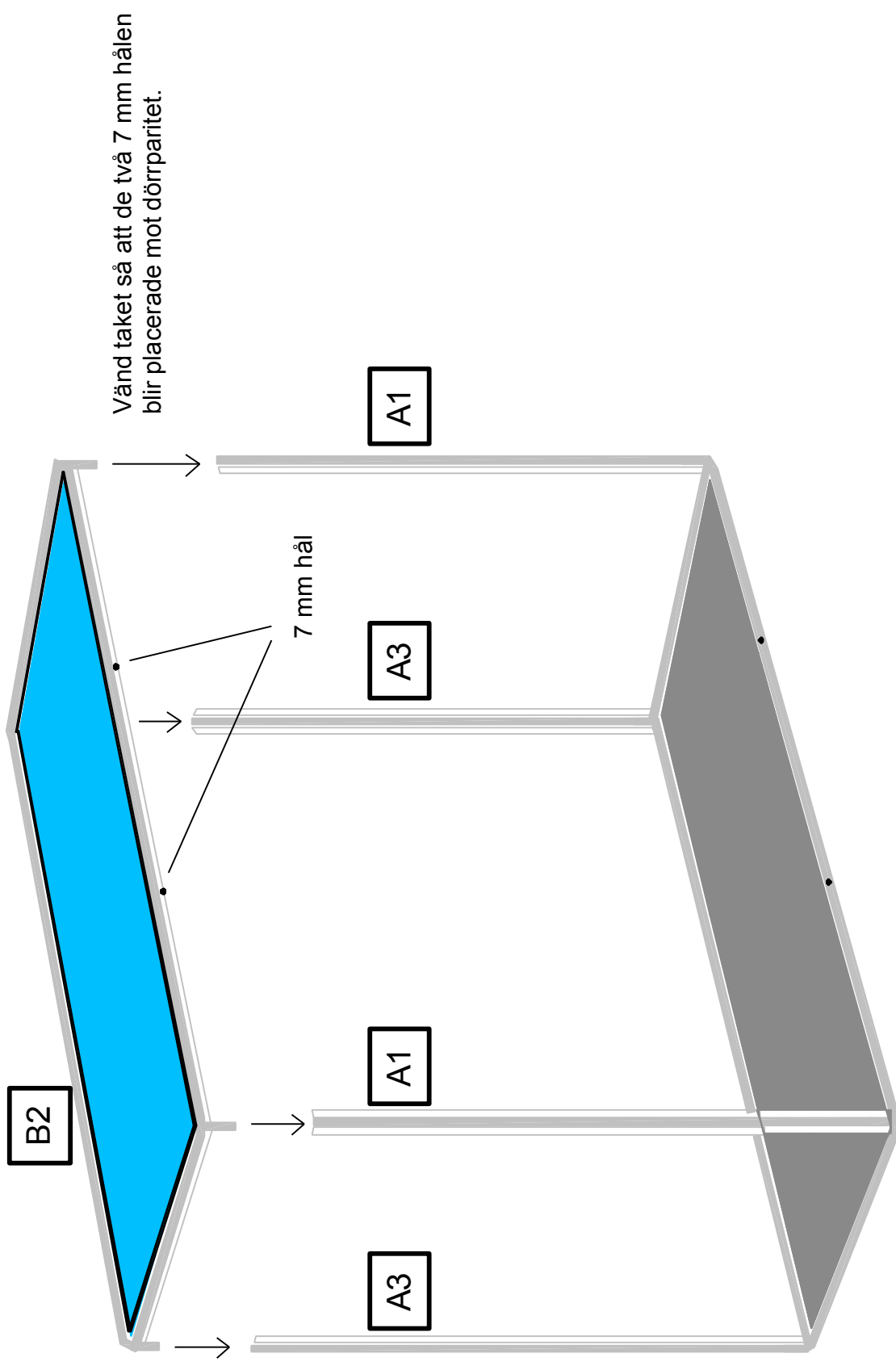

Montera bagväggarna

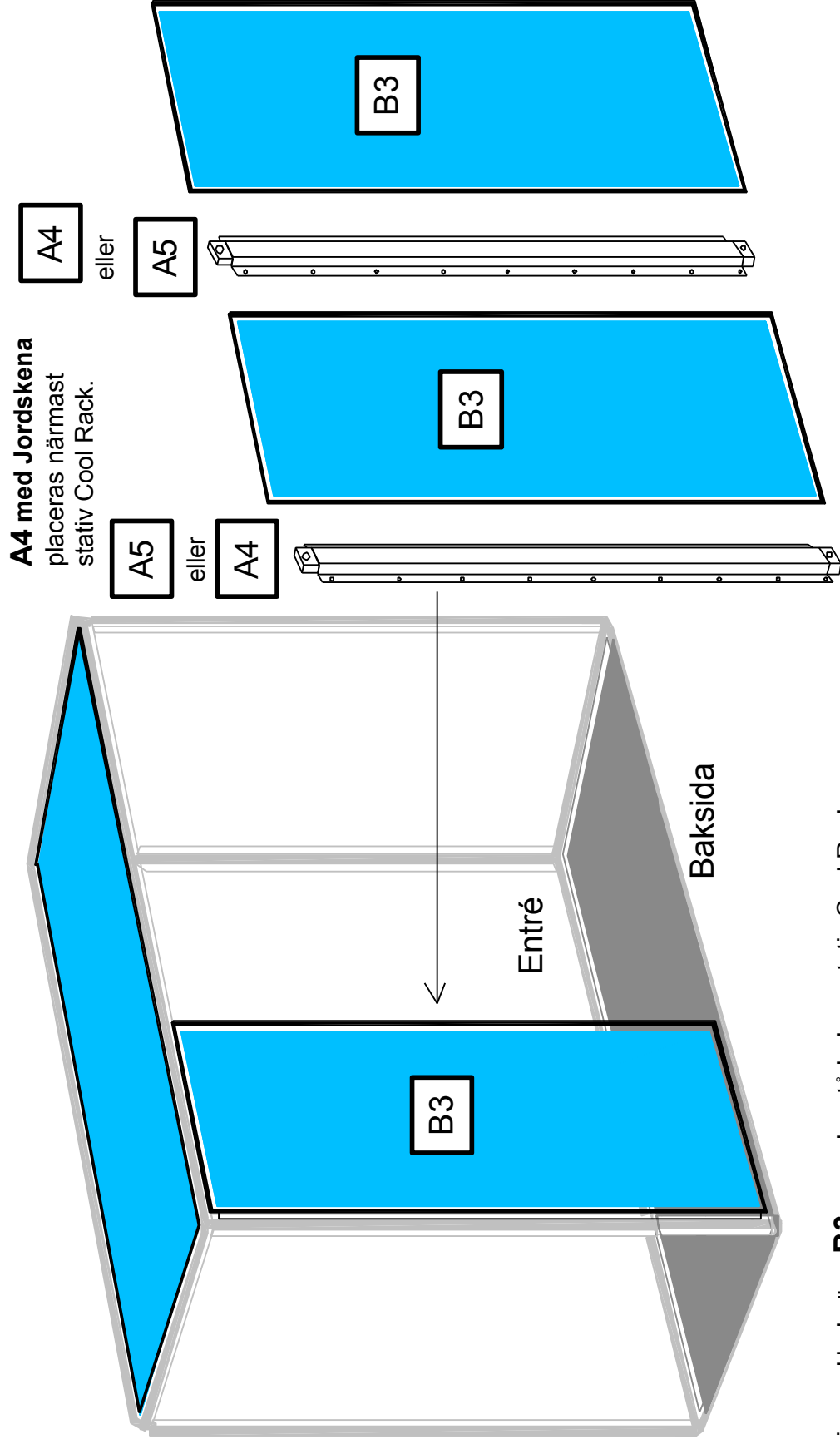

Börja med bakvägg **B3** som ska stå bakom stativ Cool Rack.
Placera därefter stolpe **A4**. Fixera med några skruv runt om.
Fortsätt att montera nästa bakvägg **B3** och stolpe **A5**. Fixera igen med några skruv.
Sist monteras den tredje bakväggen **B3** varefter alla skruvar fixeras.

Montera sidoluckor, Alternativ 1

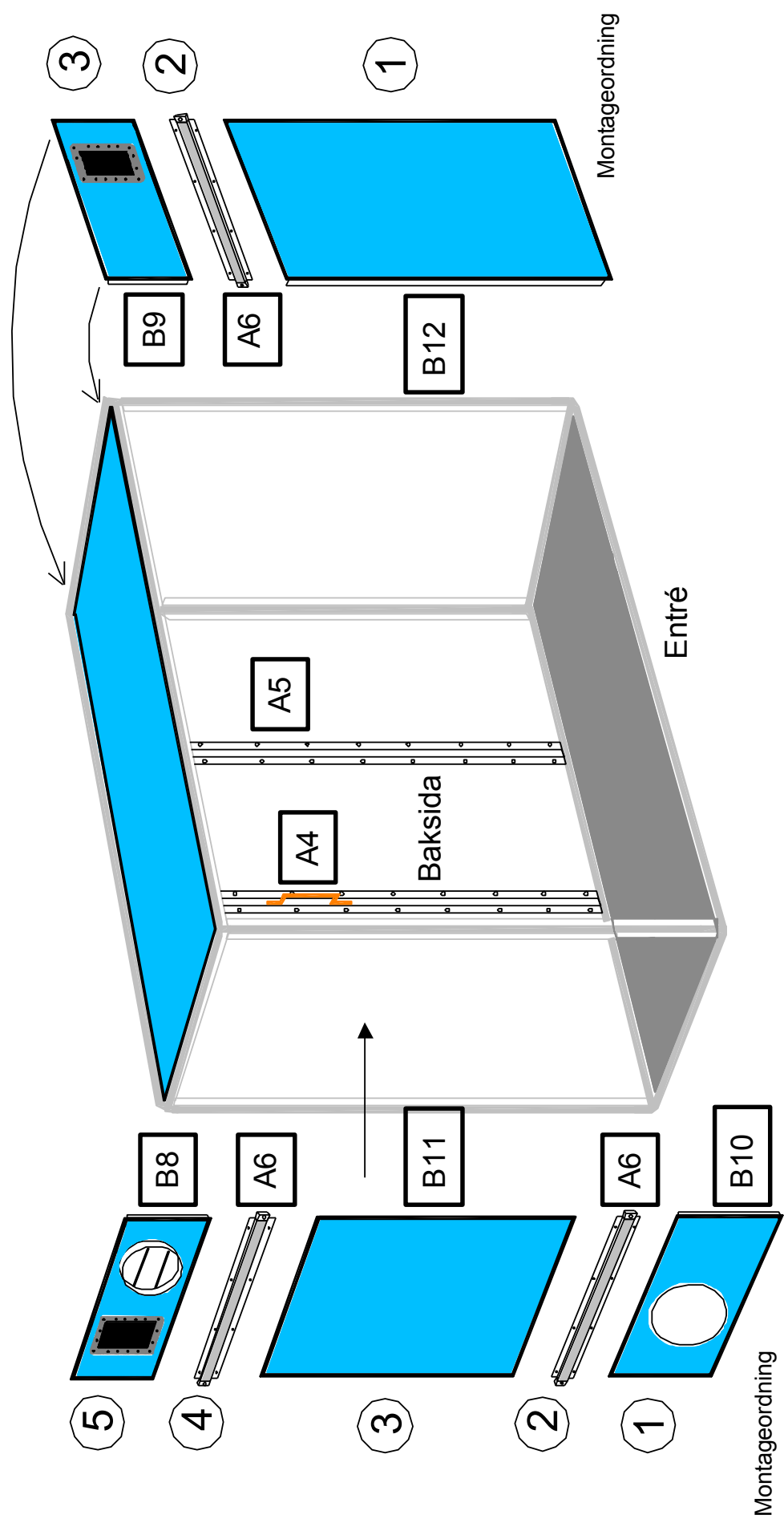

Montera sidoluckor, Alternativ 2

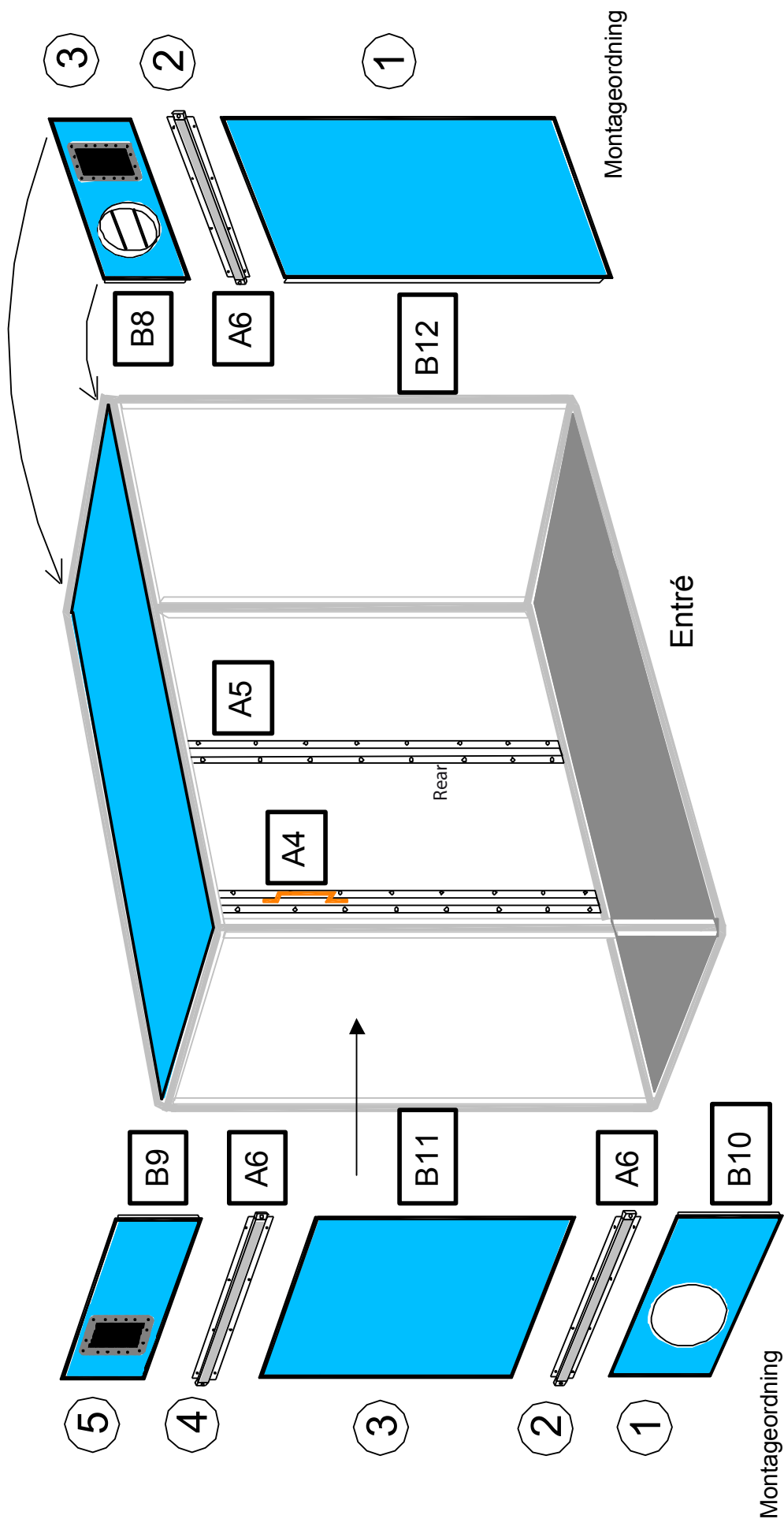

Montera sidoluckor, Alternativ 3

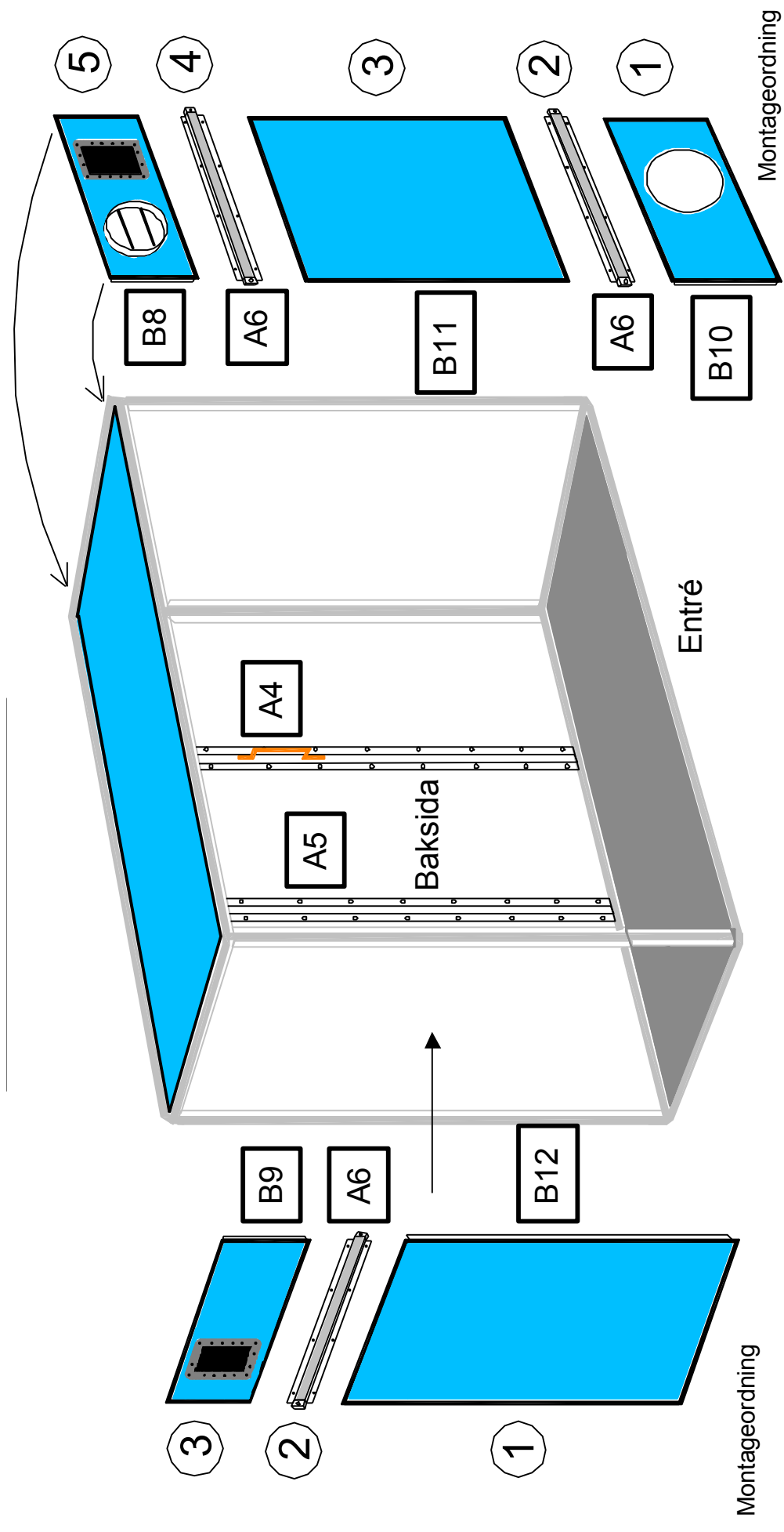

Montera sidoluckor, Alternativ 4

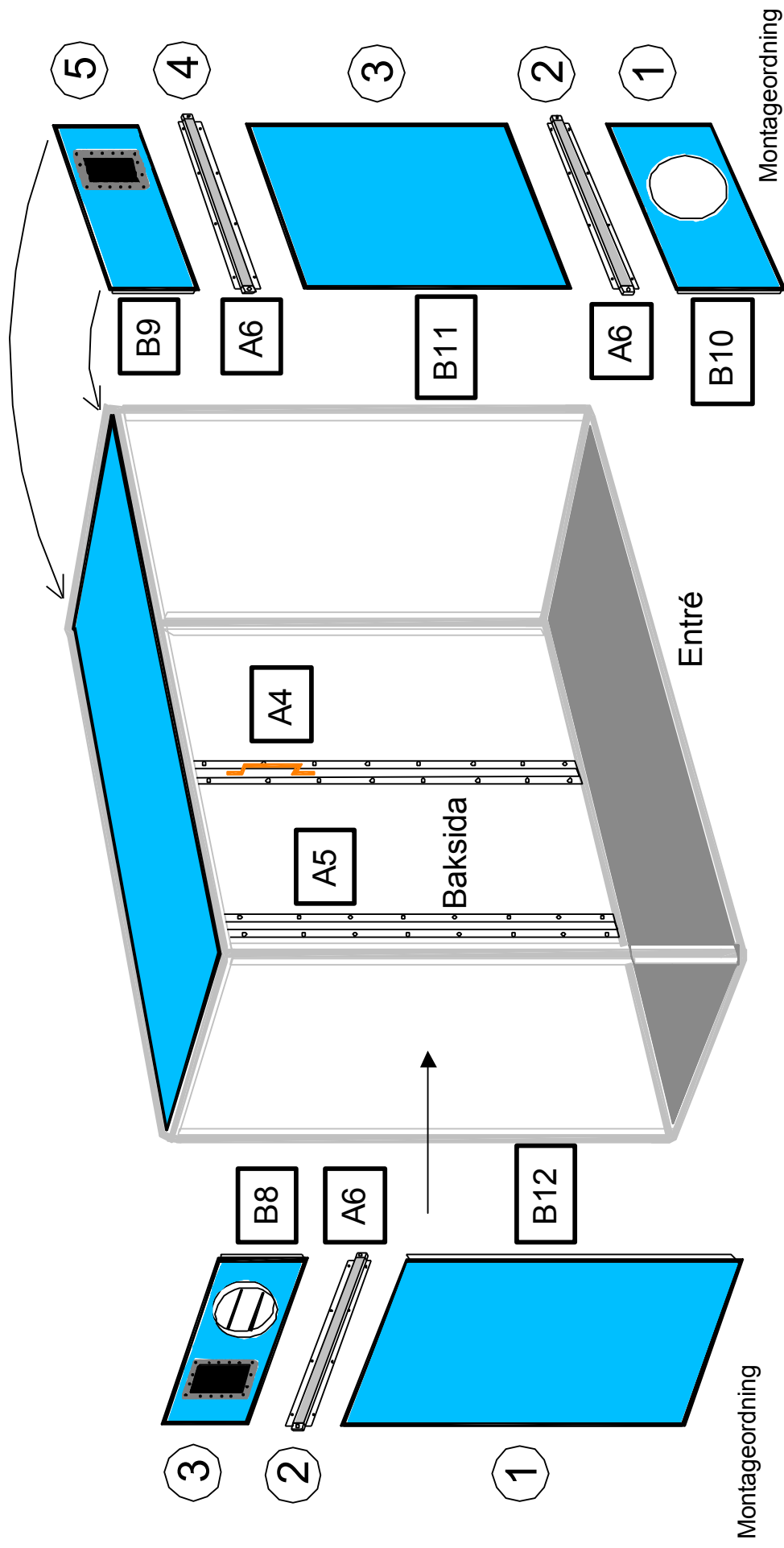

montera kabelränna

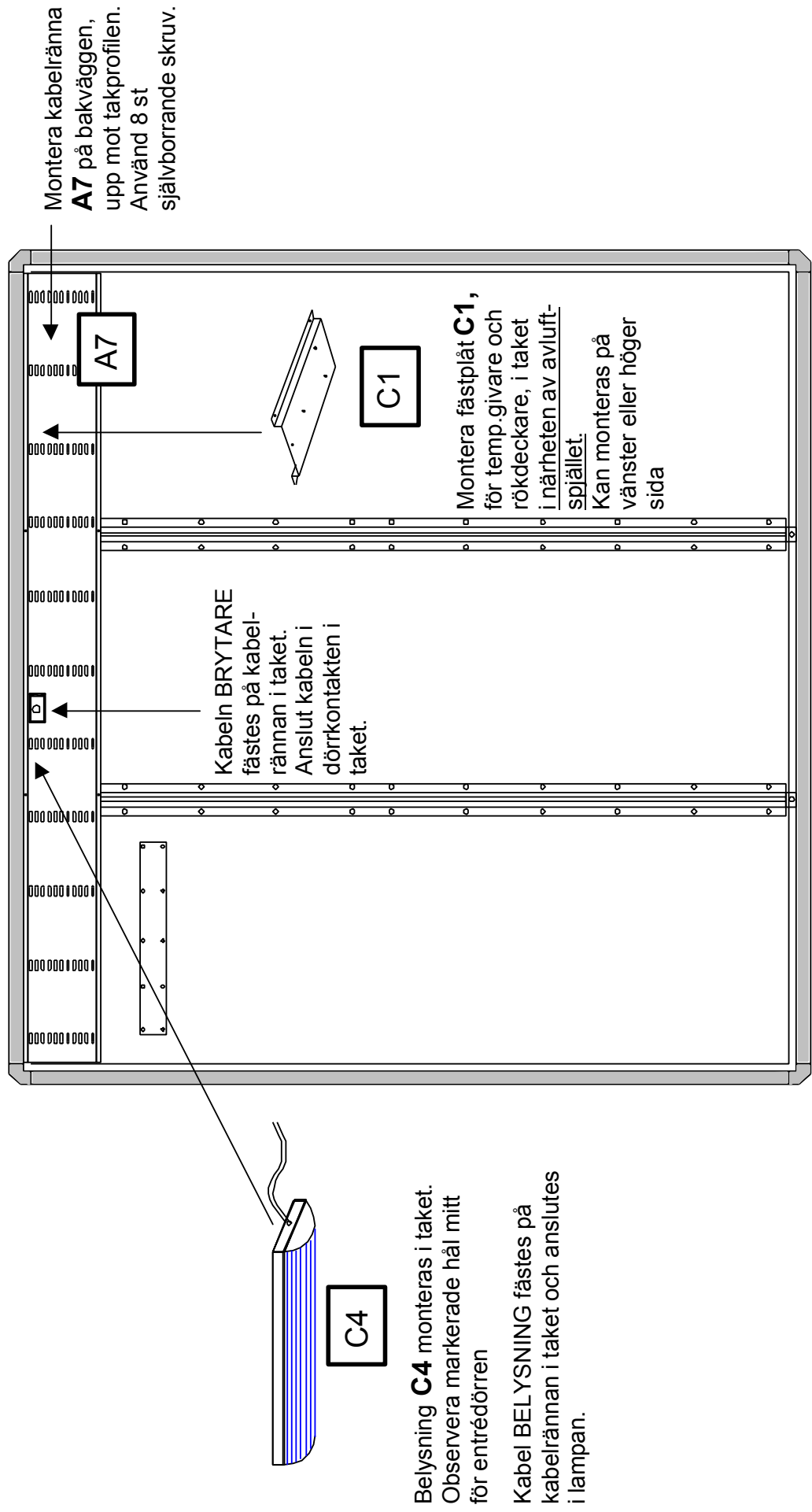

Montera coolrack

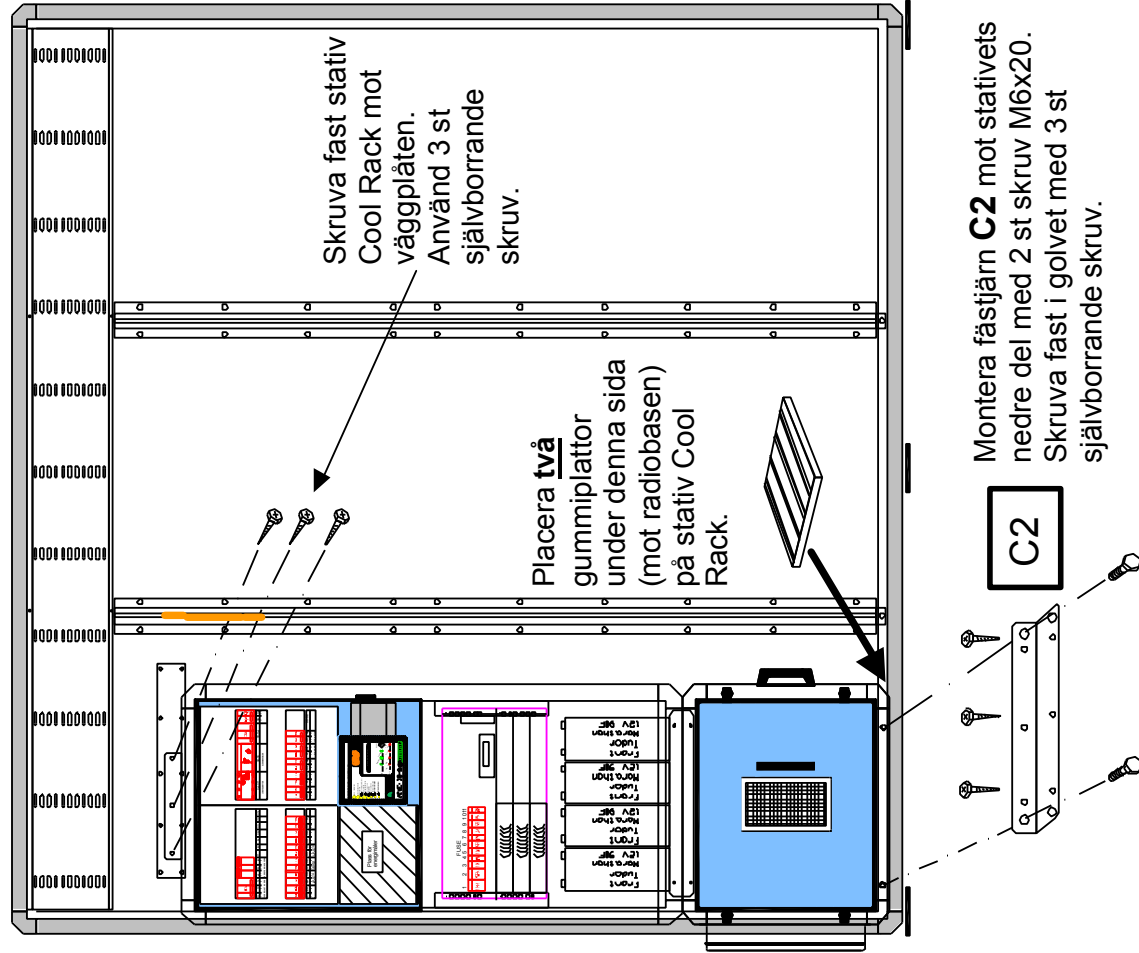

För val av sida och sammanfogning av stativet, se manual för CoolRack KS-

Montera dörrar

Stolparna **A2** monteras med stiften i 7 mm hålen. Dessa stolpar kan demonteras vid behov av full dörröppning.

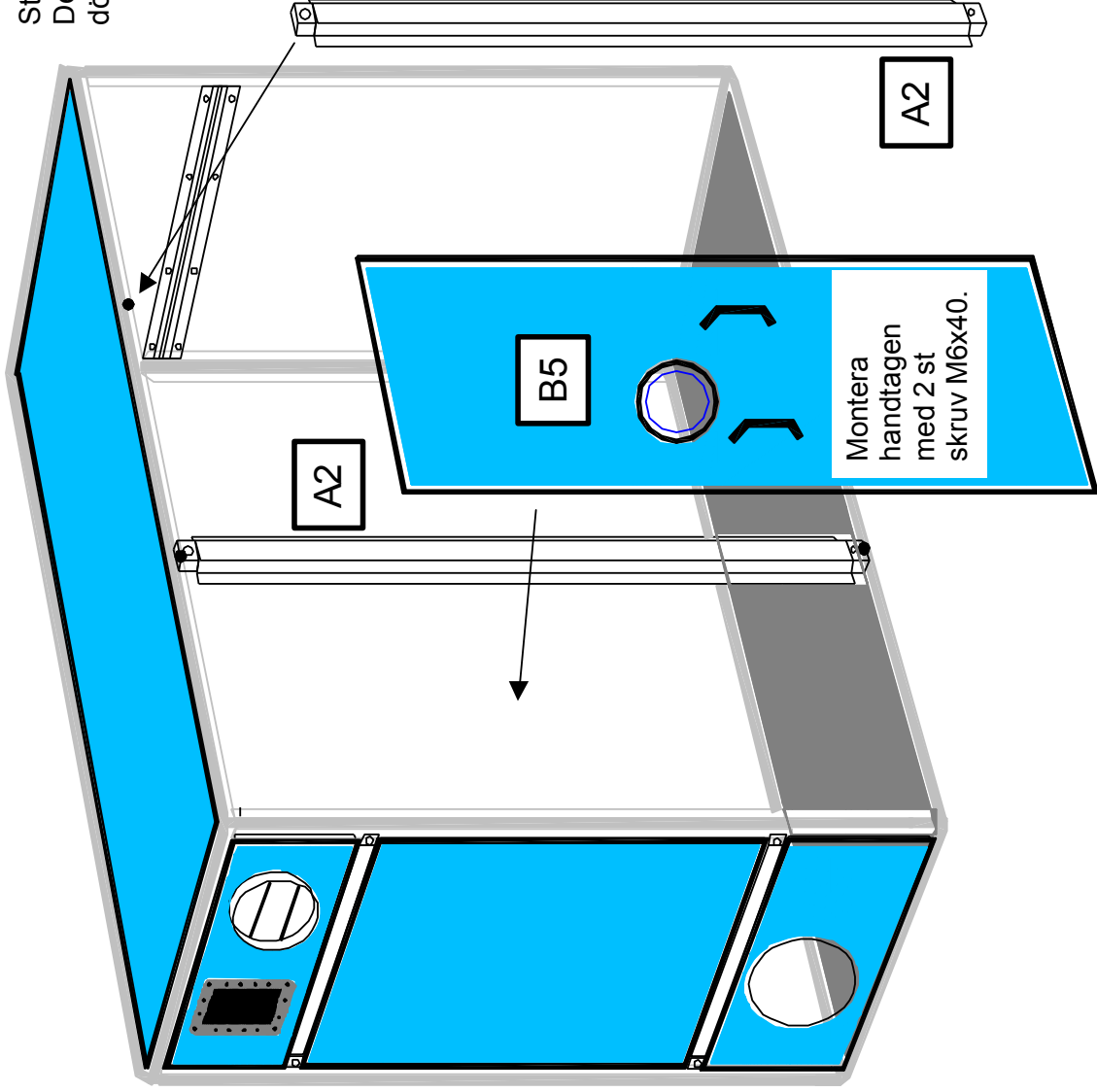

Dörr **B6** sättes alltid i mitten

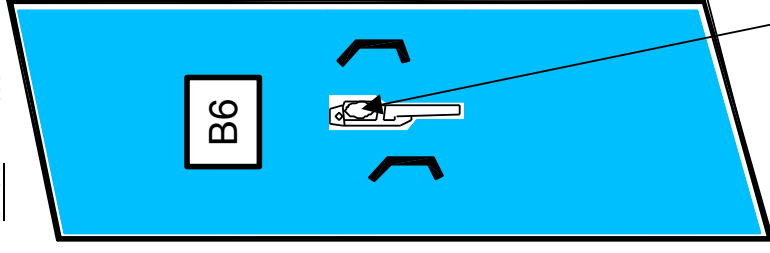

Montera låskolven med envägsskruvarna och 2 st handtag med M6x40.

Elektrisk anslutning

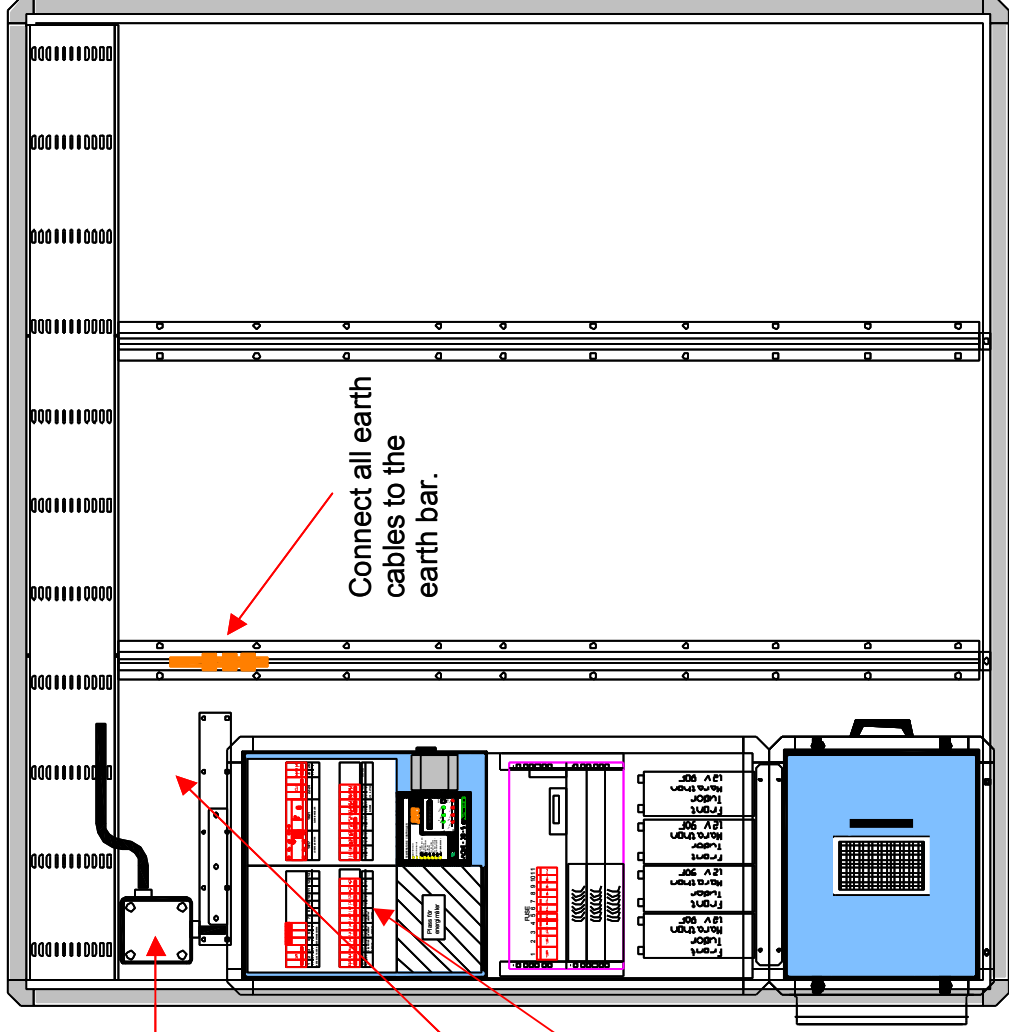

Place and fix the cable box for main power above CoolRack.

Fix the cable for lighting and switch for lighting on the cable ladder in the roof.
Place them together with cables for room temp. sensor, smoke detector (if used) and exhaust air damper motor and allow them to come down into the CoolRack.
Fix the cables inside the CoolRack.

Notice that intruder alarm (open door) can be connected to terminal 4-5 inside the 400 V module box.
The alarm contact breaks at open door = NC.

Connect all earth cables to the earth bar.

Innan du går

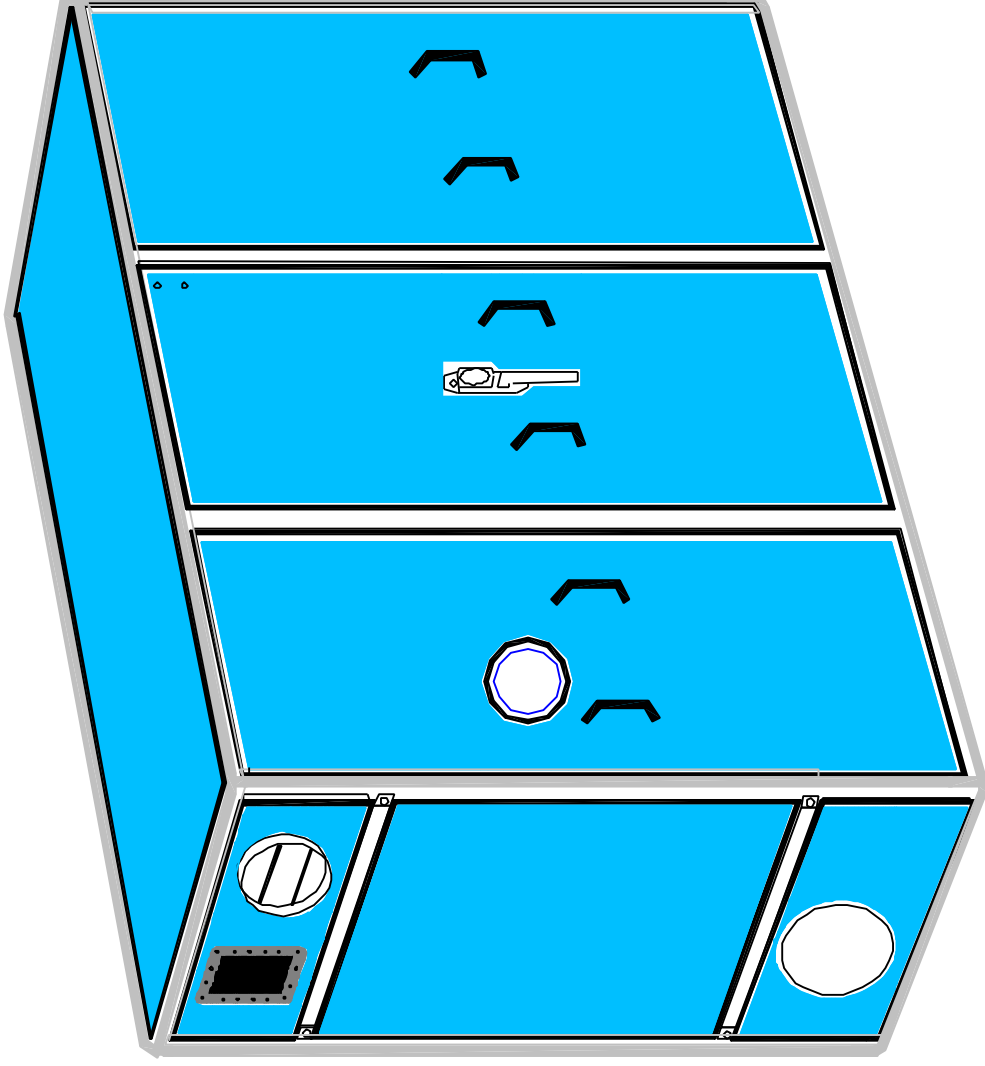

Innan Du lämnar Indoor shelter IS-2 bör Du ta bort skyddsplasten på alla blå ytor. Vi rekommenderar att åtminstone ta bort skyddsplasten på dörrarna eftersom det annars finns ökad risk för statisk elektricitet vid hantering

Contact Dantherm:

Dantherm Air Handling A/S
Marienlystvej 65
7800 Skive
Denmark

Phone +45 96 14 37 00
Fax +45 96 14 38 00

infodk@dantherm.com
www.dantherm.com

Dantherm AS
Postboks 4
3101 Tønsberg
Norway
Besøksadresse: Løkkeåsvn. 26
3138 Skallestad
Phone +47 33 35 16 00
Fax +47 33 38 51 91

dantherm.no@dantherm.com
www.dantherm.no

Dantherm Air Handling AB
Virkesgatan 5
614 31 Söderköping
Sweden

Phone +(0) 121 130 40
Fax +(0) 121 133 70

infose@dantherm.com
www.dantherm.se

Dantherm Air Handling (Suzhou) Ltd.
Bldg#9, No.855 Zhu Jiang Rd.,
Suzhou New District, Jiangsu
215219 Suzhou
China

Phone +86 512 6667 8500
Fax +86 512 6667 8500

dantherm.cn@dantherm.com
www.dantherm-air-handling.com.cn

Dantherm Limited
12 Windmill Business Park
Windmill Road, Clevedon
North Somerset, BS21 6SR
England
Phone +44 (0)1275 87 68 51
Fax +44 (0)1275 34 30 86

infouk@dantherm.com
www.dantherm.co.uk

Dantherm Air Handling Inc.
110 Corporate Drive, Suite K
Spartanburg, SC 29303
USA

Phone +1 (864) 595 9800
Fax +1 (864) 595 9810

infous@dantherm.com
www.dantherm.com



840037- R1.0

Dantherm Air Handling A/S

Marienlystvej 65
7800 Skive
Denmark

Phone +45 96 14 37 00
Fax +45 96 14 38 00

service@dantherm.com
www.dantherm.com

Dantherm[®]
CONTROL YOUR CLIMATE